

BLOCK DIAGRAM

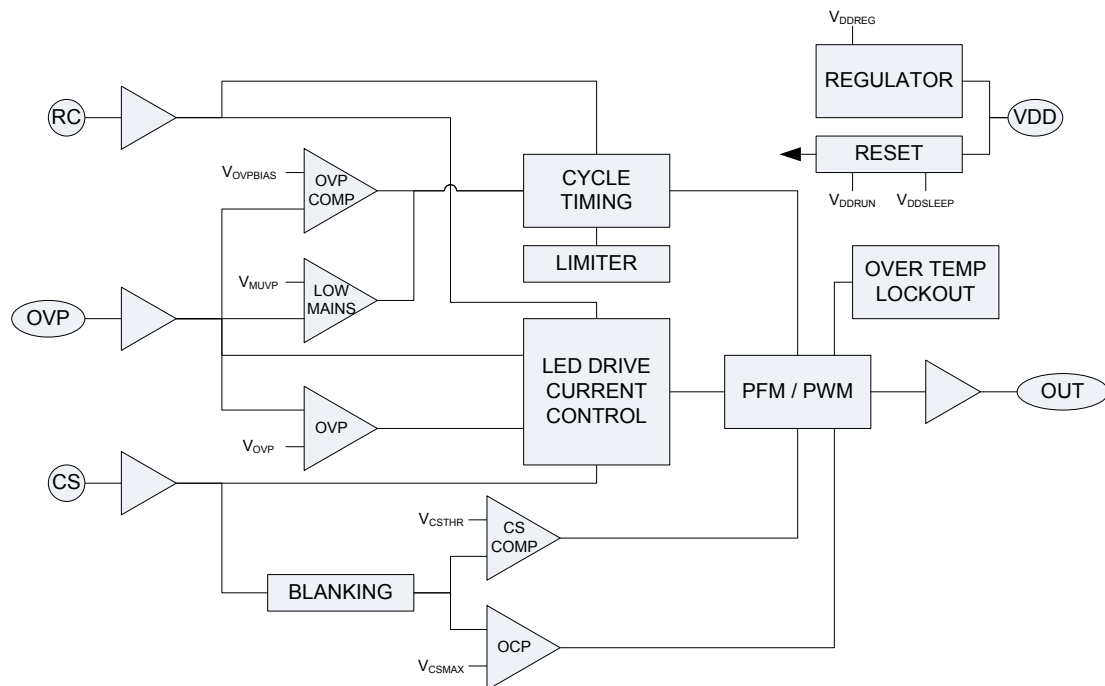

Figure 2: C3122LX2 Block Diagram

PIN DEFINITIONS

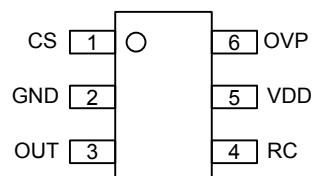

Figure 3: C3122LX2 Pin Assignment

VDD Pin

The VDD pin supplies power to the chip and dictates the operating mode (Run or Sleep).

OVP Pin

The OVP pin is used to sense the transformer winding voltage waveform, scaled and AC-coupled by an external RC network (Rovp1, Rovp2 and Covp in Figure 1).

CS Pin

The CS pin senses the primary switch current via the current sensing resistor (Rcs in Figure 1).

RC Pin

The RC timing network connected to the RC pin (shown as Rosc, Cosc in Figure 1) defines the required maximum switching frequency F_{MAX} .

OUT Pin

The OUT pin is connected to the emitter of the external bipolar junction transistor (Q1 in Figure 1).

GND Pin

The GND pin provides the ground reference.

PRINCIPLE OF OPERATION

Parameters used in equations are explained in the Electrical Characteristics section.

Power-Up/Power-Down Sequences

The C3122LX2 controller is powered via the VDD pin. When the line input is first applied, a small amount of current ($I_{DD\text{SLEEP}}$) is drawn from the rectified mains input via a high value start up resistor (R_{ht} in Figure 1). When the voltage on the VDD pin (V_{DD}) reaches a level $V_{DD\text{RUN}}$ the controller wakes up, demands more supply current ($I_{DD\text{REG}}$) and enters the Initialise mode (see Figure 5). The controller stays in Initialise for a short time during which internal circuits are enabled and then changes to Run mode. In Run mode, the controller uses an internal shunt regulator to regulate V_{DD} at $V_{DD\text{REG}}$.

If the VDD pin voltage drops $\Delta V_{DD\text{SLEEP}}$ below $V_{DD\text{REG}}$ the controller goes back into Sleep mode, reducing the supply current demand. The system will restart when input power is restored and V_{DD} reaches $V_{DD\text{RUN}}$ again. To achieve a smooth power up sequence the VDD reservoir capacitor (C_{dd} in Figure 1) needs to be large enough to sustain the supply over the Initialise period and the first few cycles of Run mode, until the auxiliary rail voltage supply is established.

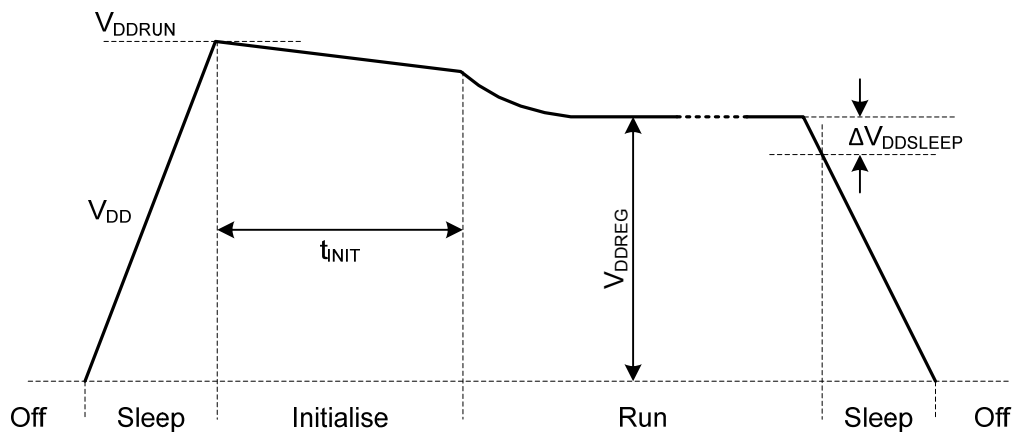

Figure 5: VDD Pin Waveform (V_{DD})

Mode	Description
Sleep	From initial application of power or from Run mode if V_{DD} falls below $\Delta V_{DD\text{SLEEP}}$ below $V_{DD\text{REG}}$, the controller changes to Sleep mode. Non-essential controller circuits are powered down and the external switching transistor (Q1) is held off. Exit from Sleep mode occurs when V_{DD} rises above $V_{DD\text{RUN}}$ and the controller moves to the Initialise mode.
Initialise	When Initialise mode is entered, internal controller circuits are initialised and two clock cycles are issued, after which the controller changes from Initialise to Run mode.
Run	Converter operation continues. The shunt regulator controls V_{DD} to $V_{DD\text{REG}}$. If V_{DD} falls $\Delta V_{DD\text{SLEEP}}$ below $V_{DD\text{REG}}$, the controller ceases power conversion and reverts to Sleep mode.

Table 1: Summary of Controller Modes

Constant Current (CC) Operation

The C3122LX2 controller achieves constant current output within tight limits without the need for any secondary sensing components, by sensing the primary side waveforms of transformer voltage and primary switch current. Figure 6 shows the output current characteristics of a typical solid state lighting application using the C3122LX2.

The current flowing through the transformer primary winding is sensed on the CS pin by the voltage generated across the current sensing resistor (R_{CS} in Figure 1). The voltage seen on the CS pin is a negative-going voltage waveform as shown in Figure 7. When the voltage on the CS pin exceeds a (negative) threshold $V_{CS_{THR}}$, the primary switching transistor is rapidly turned off. The internal loop controller regulates the CS voltage threshold ($V_{CS_{THR}}$ in Figure 7) between $V_{CS_{MIN}}$ and $V_{CS_{MAX}}$, based on the average CS input voltage and CC regulation set point ($V_{CS_{CC}}$) to achieve constant output current regulation. Blanking is provided for a period of $t_{CS_{B1}}$ to prevent false triggering due to leading edge spikes in the waveform.

Constant Current regulation is determined by the transformer turns ratio and the value of R_{CS} . The value of R_{CS} is determined by the required output current (I_{OUT}) and transformer primary-secondary turns ratio (N_P/N_S) according to the approximation:

$$R_{CS} \approx \left(\frac{N_P}{N_S} \right) \left(\frac{V_{CS_{CC}}}{I_{OUT}} \right)$$

The tolerance of R_{CS} has a direct relationship to the accuracy of the output current limit and is typically chosen to be 1%.

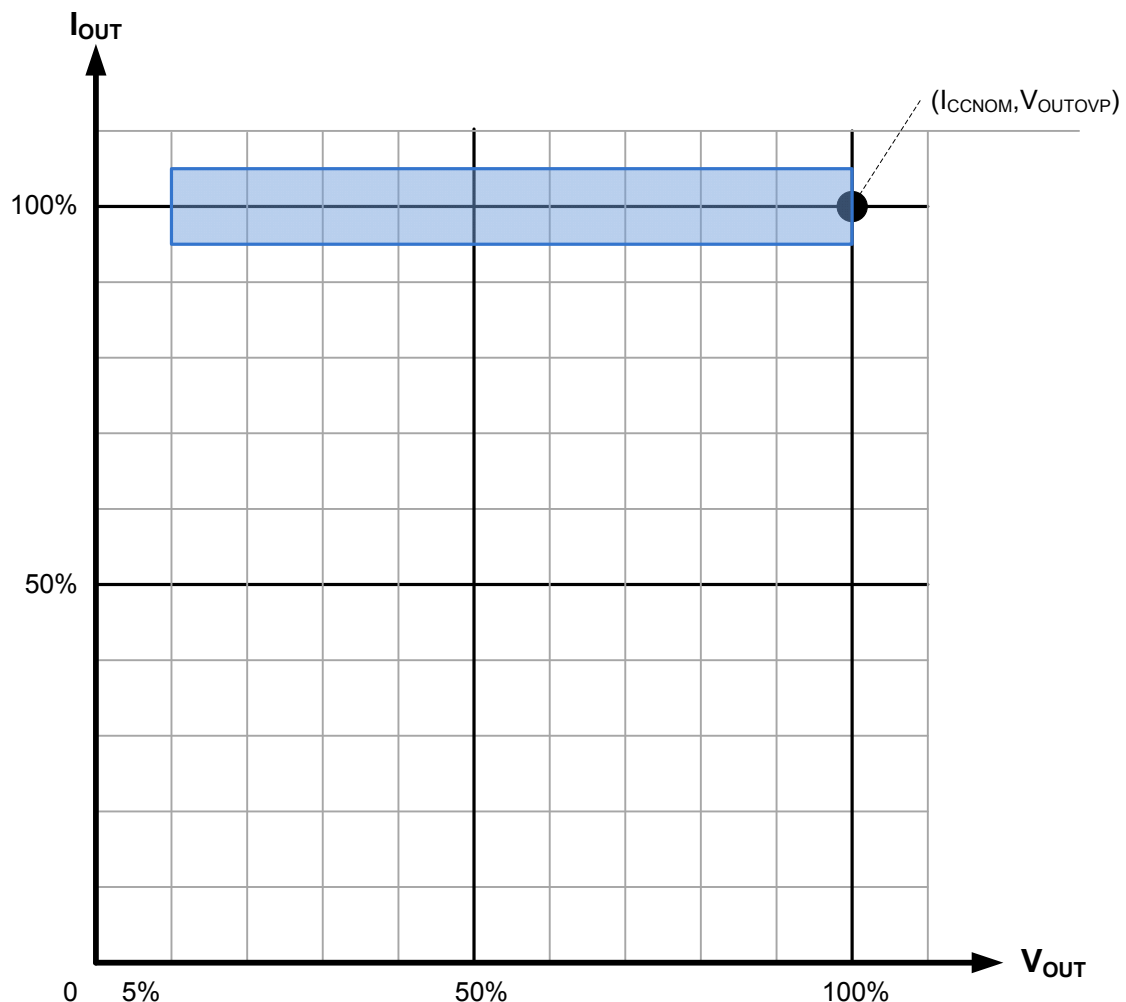

Figure 6: Typical Load Regulation Using C3122LX2

Switching Waveforms

Typical switching waveforms for the OVP, CS and RC inputs are shown with the OUT output in Figure 7.

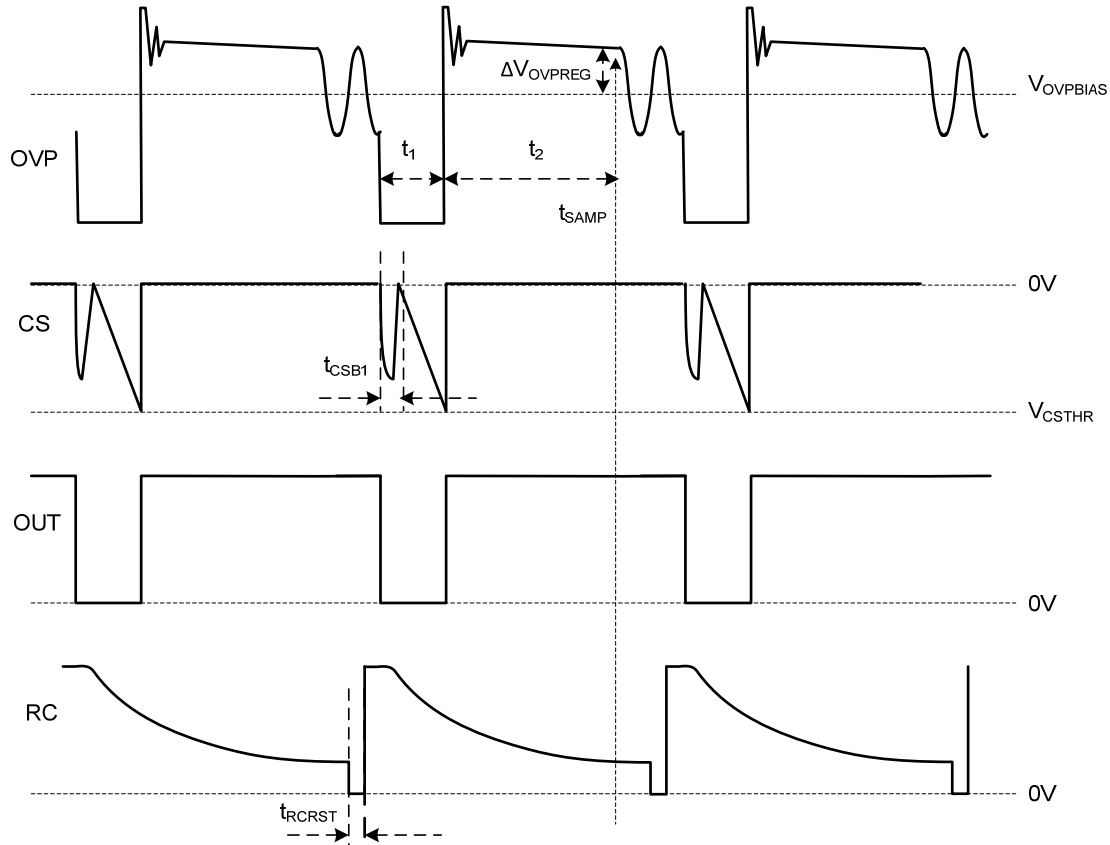

Figure 7: Typical Waveforms: OUT, OVP, CS, RC pins

Drive Pulse and Frequency Modulation

The C3122LX2 controls both the primary switch peak current and the switching frequency in response to the power demanded by the application load. The controller ensures that power conversion is performed in discontinuous conduction mode (DCM) at all times. The switching frequency is varied depending on the actual power demand. The maximum switching frequency is set by F_{MAX} . The C3122LX2 controller does not have a minimum switching frequency. The full-load frequency F_{MAX} (chosen in the range 40 to 66 kHz) is set by the equations:

$$F_{MAX} = \frac{1}{K_{OSC} \cdot \tau_{RCOSC} + t_{RCRST}}$$

The oscillator time constant τ_{RCOSC} is controlled by external components C_{OSC} , R_{OSC} so that:

$$\tau_{RCOSC} = R_{OSC} \cdot C_{OSC}$$

Duty Cycle Control

The maximum duty cycle is set by the primary-secondary turns ratio (N_P/N_S) of the transformer (typically 16:1 for a 5 V output). For a typical universal input offline application, a maximum duty cycle of 50% is chosen for the minimum rectified supply voltage (typically $80 V_{DC}$).

Soft Switching

Zero current (quasi-resonant) switching is used to minimise the switching losses in the primary switch, thereby increasing efficiency and introducing frequency jitter, to spread the RF emissions spectrum. The primary switching BJT is turned on when the voltage across it is a minimum (as detected by the OVP input), minimising the capacitive switching losses and reducing the RF emissions.

Cascode Switching

The primary switch is connected in cascode configuration to ensure fast and efficient switching using low-cost bipolar transistors, e.g. MJE13002, STX13003, STBV42, STBV45, TS13003MV. The slew rate of the OUT drive pin is limited to minimise conducted and radiated EMI.

Protection Features

Short-Circuit Protection

If required, the application circuit can be forced to hiccup if the output is short-circuit. This is achieved by designing the auxiliary winding on the transformer (T1) so that the auxiliary rail voltage (at the cathode of Daux) is too low, allowing the VDD pin to fall by at least $\Delta V_{\text{DDSL}}E E P$ below V_{DDREG} . The controller will repeatedly switch between Sleep and Run modes, resulting in low power consumption. (When the short-circuit condition is removed, the application returns to normal operation.)

Mains Under Voltage Protection (MUVP) and Over Voltage Protection (MOVP)

The regulated output voltage is reduced when the rectified input voltage falls outside the normal working voltage range, defined by V_{MUVP} and V_{MOVP} . The value is defined by the nominal output voltage (V_{OUTOVP}), the primary-secondary turns ratio (N_P/N_S) and other IC parameters by the equation:

$$V_{\text{MUVP}} \approx V_{\text{OUTOVP}} \frac{N_P}{N_S} \frac{|\Delta V_{\text{MUVP}}|}{\Delta V_{\text{OVPREG}}} \qquad V_{\text{MOVP}} \approx V_{\text{OUTOVP}} \frac{N_P}{N_S} \frac{V_{\text{OVPBIAS}}}{\Delta V_{\text{OVPREG}}}$$

Over Temperature Protection (OTP)

The on-chip OTP is triggered if the junction temperature exceeds the threshold T_{SH} , shutting down the controller. To prevent possible damage to the PCB, the OTP prevents restarting until the temperature has dropped to $(T_{\text{SH}} - T_{\text{SHHYST}})$.

Primary Switch Over Current Protection (OCP)

The primary switch is turned off if the primary switch current exceeds a preset threshold V_{CSMAX} , as sensed by the CS input, subject to the minimum on-time T_{ONMIN} . This gives pulse by pulse over current protection.

Output Over Voltage Protection

Output over voltage protection is achieved by sensing the OVP input, which is AC coupled to the auxiliary winding of the transformer, as shown in Figure 1. The OVP pin is internally biased to V_{FBIAS} . A typical voltage waveform seen on this pin is shown in Figure 7.

The output over voltage set point should be a little over the maximum forward voltage drop of the LED string and is determined by the selection of the potential divider resistors (Rovp1, Rovp2 in Figure 1) and the chosen transformer turns ratio. The total parallel combination of these resistors should be typically less than 120 Ω to prevent unwanted effects of stray capacitance. Values of Rovp1, Rovp2 and Covp are given by the equations:

$$\begin{aligned} \text{Rovp2} &= 120 \, \Omega \\ \text{Covp} &= 47\text{nF} \pm 20\% \\ \text{Rovp1} &= \frac{\text{Rovp2} \left(V_{\text{OUTOVP}} \frac{N_F}{N_S} - \Delta V_{\text{OVPREG}} \right)}{\Delta V_{\text{OVPREG}}} \end{aligned}$$

ABSOLUTE MAXIMUM RATINGS

CAUTION: Permanent damage may result if a device is subjected to operating conditions at or in excess of absolute maximum ratings.

Parameter	Symbol	Condition	Min	Max	Unit
Supply voltage	V_{DD}		-0.5	4.5	V
Supply current	I_{DD}		-20	90	mA
OVP input voltage	V_{OVP}	DC condition	-0.5	$V_{DD} + 0.5$	V
CS input voltage	V_{CS}		-0.5	$V_{DD} + 0.5$	V
RC input voltage	V_{RC}		-0.5	$V_{DD} + 0.5$	V
OUT pin voltage	V_{OUT}		-0.5	$V_{DD} + 0.5$	V
OVP input current	I_{OVP}		-20	20	mA
CS input current	I_{CS}		-20	20	mA
RC input current	I_{RC}		-35	250	mA
OUT pin current	I_{OUT}		-20	650	mA
Junction temperature	T_J		-25	125	°C
Storage temperature	T_P		-40	150	°C
Lead temperature	T_L	Soldering, 10 s		260	°C
ESD withstand		Human body model, JESD22-A114		2	kV
		Charged device Model, ANSI-ESD-STM5.3.1		500	V

NORMAL OPERATING CONDITIONS

Unless otherwise stated, electrical characteristics are defined over the range of normal operating conditions. Functionality and performance is not defined when a device is subjected to conditions outside this range and device reliability may be compromised.

Parameter	Symbol	Condition	Min	Typ	Max	Unit
Supply voltage	V_{DD}		3.1	3.45	3.6	V
Supply current	I_{DD}				30	mA
Full power switching frequency	F_{NOM}	Full-load, application dependent	36	40	66	kHz
Transformer resonance frequency (in-circuit)	F_{RES}		300			kHz
Junction temperature	T_J		-25	25	105	°C

ELECTRICAL CHARACTERISTICS

Unless otherwise stated:

1. Min and Max electrical characteristics apply over normal operating conditions.
2. Typical electrical characteristics apply at $T_J = T_{J(TYP)}$ and $I_{DD} = I_{DDREG(TYP)}$.
3. The chip is operating in Run mode.
4. Voltages are specified relative to the GND pin.

VDD Pin

Parameter	Symbol	Condition	Min	Typ	Max	Unit
Supply voltage	V_{DDRUN}	To enter Initialise mode	3.6	4.0	4.45	V
	V_{DDREG}	In Run mode	3.3	3.45	3.6	V
	$\Delta V_{DDSLLEEP}$	To enter Sleep mode (measured relative to V_{DDREG})		-600		mV
Supply current	I_{DDREG}	In Run mode			2.4	mA
	$I_{DDSLLEEP}$	In Sleep mode			5.5	μ A
Initialisation time	t_{INIT}			$3\tau_{RCOSC}$		s

OVP Pin

Parameter	Symbol	Condition	Min	Typ	Max	Unit
OVP bias voltage	V_{OVPIAS}	Internal DC bias voltage	1.66		1.84	V
OVP regulation level	ΔV_{OVPREG}	Measured relative to V_{OVPIAS} $T=25^\circ\text{C}$	394.5	405	415.5	mV
OVP slope detection threshold	$\Delta V_{OVP}/\Delta t$		-280	-200	-120	mV/ μ s
OVP input resistance	R_{OVPIN}	Effective input resistance $0 < V_{OVP} < V_{DD}$		50		k Ω
OVP initialisation current	I_{FBINIT}	$V_{OVP} = 0\text{ V}$		-1.8		mA
Mains UVP comparator threshold offset	ΔV_{MUVPT}	Measured relative to V_{OVPIAS}		-135		mV

RC Pin

Parameter	Symbol	Condition	Min	Typ	Max	Unit
Maximum switching frequency	F_{MAX}	$220\text{ pF} < C_{OSC} < 2.2\text{ nF}$	30		66	kHz
Maximum frequency control factor	K_{OSC}			0.31		
Oscillator reset time	t_{RCRST}			2.7	3.8	μ s

CS Pin

Parameter	Symbol	Condition	Min	Typ	Max	Unit
CS input minimum threshold	V_{CSMIN}	Outside CS blanking time t_{CSB1}	Minimum load	-38		mV
CS input maximum threshold	V_{CSMAX}		Over-current protection	-182		mV
CS turn-off response time	t_{CSOFF}		Step ΔV_{CS} : $V_{CSMAX} + 10$ mV to $V_{CSMAX} - 10$ mV	175		ns
CS Input Offset	ΔV_{CSOFF}			0		μ V
CS Input Leakage Current	I_{CSLEAK}	-0.2 V < V_{CS} < V_{DD}	-10		10	μ A
CS input limit for CC operation (average)	V_{CSCC}	F = 40 kHz, $t_1 = t_2 = 12.5$ μ s, T=25°C	-32.5	-31.4	-30.3	mV
Leading edge blanking time	t_{CSB1}	See Figure 7		400		ns

OUT Pin

Parameter	Symbol	Condition	Min	Typ	Max	Unit
On-state resistance	R_{OUTON}	$I_{OUT} < I_{OUT(MAX)}$		0.9	1.25	Ω
Off-state current	I_{OUTOFF}	$V_{OUT} = V_{DD}$			10	μ A
Minimum on-time	t_{ONMIN}			575		ns

THERMAL CIRCUIT PROTECTION

Parameter	Symbol	Condition	Min	Typ	Max	Unit
Thermal shutdown temperature	T_{SH}	At silicon junction	105	115	125	°C
Thermal shutdown hysteresis	T_{SHHYST}	At silicon junction		30		°C

PACKAGE THERMAL RESISTANCE CHARACTERISTICS

Conditions:

1. Controller IC mounted on typical PCB (1.6 mm thick, 35 μ m copper, CEM1);
2. θ_{JB} measured to pin terminal of device at the surface of the PCB.

Package	Junction-to-board θ_{JB} (Typical)	Junction-to-ambient θ_{JA} (Typical)	Units
SOT23-6	60	170	°C / W

PACKAGING AND ORDERING INFORMATION

Package Marking

The SOT23-6 package is marked with a short code indicating type and production lot as shown in Figure 8.

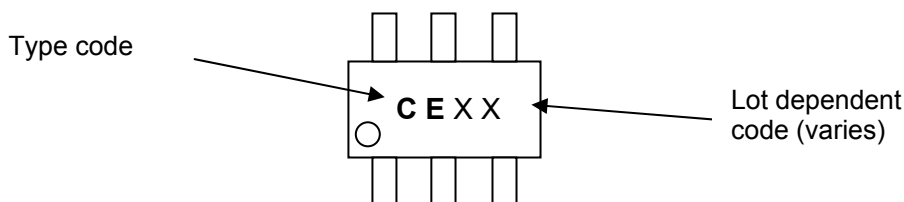

Figure 8: SOT23-6 Package Marking

Ordering

Type	Package	Marking	Packing Form	Shipping
C3122LX2	SOT23-6	CExx	7" Tape & Reel	C3122LX2-TR7
			13" Tape & Reel	C3122LX2-TR13

For further package and ordering information, please contact CamSemi.

DATASHEET STATUS

The status of this Datasheet is shown in the footer. Always refer to the most current version.

Datasheet Status	Product Status	Definition
Product preview	In development	The Datasheet contains target specifications relating to design and development of the described IC product. Application circuits are illustrative only. Specifications are subject to change without notice.
Preliminary	In qualification	The Datasheet contains preliminary specifications relating to functionality and performance of the described IC product. Application circuits are illustrative only. Specifications are subject to change without notice.
Product data	In production	The Datasheet contains specifications relating to functionality and performance of the described IC product which are supported by testing during development and production. Application circuits are illustrative only. Specifications are subject to change without notice.

CONTACT DETAILS

Cambridge Semiconductor Ltd
 St Andrew's House
 St Andrew's Road
 Cambridge
 CB4 1DL
 United Kingdom

Phone: +44 (0)1223 446450
 Fax: +44 (0)1223 446451
 Email: sales.enquiries@camsemi.com
 Web: www.camsemi.com

DISCLAIMER

The product information provided herein is believed to be accurate and is provided on an "as is" basis. Cambridge Semiconductor Ltd (CamSemi) assumes no responsibility or liability for the direct or indirect consequences of use of the information in respect of any infringement of patents or other rights of third parties. Cambridge Semiconductor Ltd does not grant any licence under its patent or intellectual property rights or the rights of other parties.

Any application circuits described herein are for illustrative purposes only. In respect of any application of the product described herein Cambridge Semiconductor Ltd expressly disclaims all warranties of any kind, whether express or implied, including, but not limited to, the implied warranties of merchantability, fitness for a particular purpose and non-infringement of third party rights. No advice or information, whether oral or written, obtained from Cambridge Semiconductor Ltd shall create any warranty of any kind. Cambridge Semiconductor Ltd shall not be liable for any direct, indirect, incidental, special, consequential or exemplary damages, howsoever caused including but not limited to, damages for loss of profits, goodwill, use, data or other intangible losses.

The products and circuits described herein are subject to the usage conditions and end application exclusions as outlined in Cambridge Semiconductor Ltd Terms and Conditions of Sale which can be found at www.camsemi.com/legal.

Cambridge Semiconductor Ltd reserves the right to change specifications without notice. To obtain the most current product information available visit www.camsemi.com or contact us at the address shown above.