

### Rapidly Implement Application Circuits in the Range 6 W to 40 W Using CamSemi's RDFC Topology and Advanced Controller ICs

**C2472PX2 (SOT23-6) C2473PX1 (SOP-8)**

CamSemi's RDFC topology and advanced controller ICs deliver low cost replacements for linear power supplies in plug top adapters, embedded applications and battery chargers. As well as costing less, RDFC solutions readily achieve better overload protection, efficiency and standby performance than competing linear designs.

By fixing some design parameters, this guide enables users rapidly to create a working RDFC prototype with rated output in the range 6 W to 40 W. Components are selected from simple lookup tables and transformer construction is explained. Other design guides explain how RDFC solutions can be optimised to meet particular application requirements. To obtain these guides and the RDFC controller IC datasheet (reference DS-1423) please visit [www.camsemi.com](http://www.camsemi.com).

Figure 1 illustrates a typical RDFC application circuit. Using this guide, the user can quickly select component values to create such a power supply design, with chosen input voltage, power rating and output voltage. A fully worked RDFC design example (which was created using this guide) is described in section 5 (page 24).

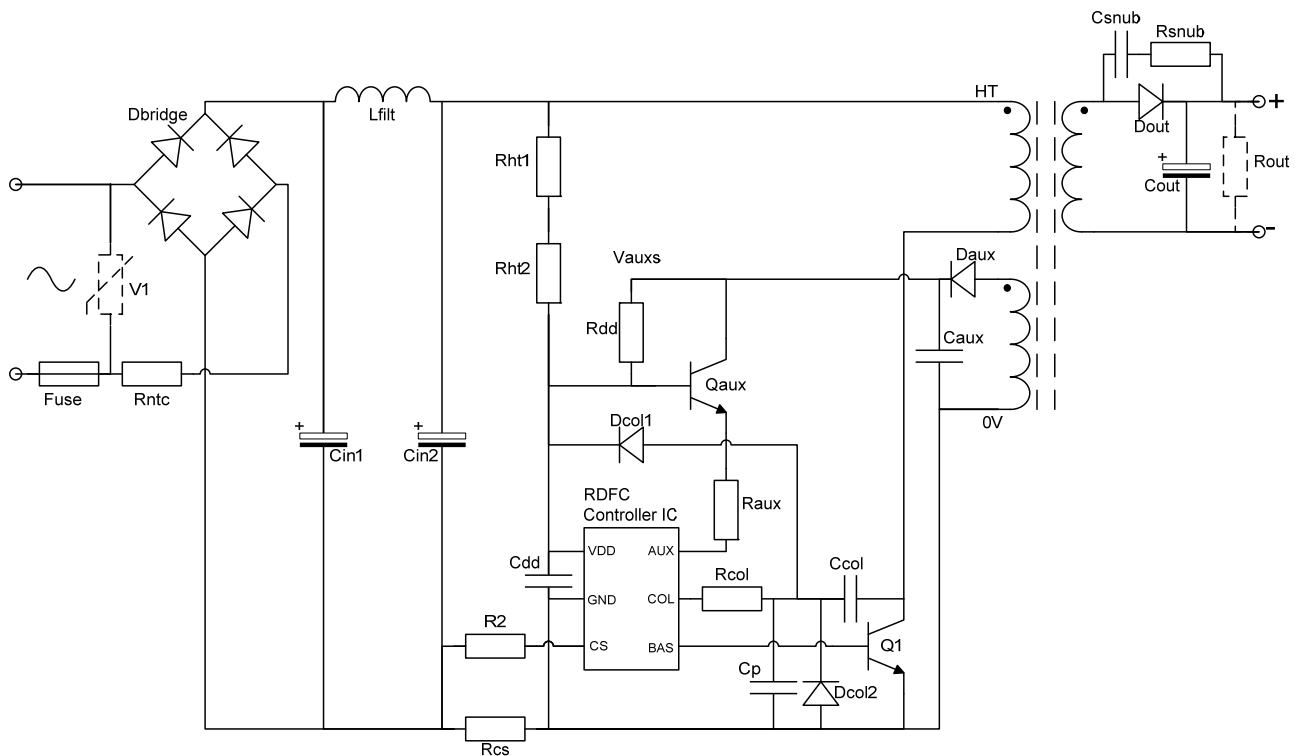

Figure 1: Typical RDFC Application Circuit

### Contents

<b>1</b>	<b>COMPONENTS IN A TYPICAL RDFC APPLICATION DESIGN</b> .....	<b>3</b>
<b>2</b>	<b>APPLICATION DESIGN PARAMETERS</b> .....	<b>4</b>
<b>3</b>	<b>COMPONENT SELECTION</b> .....	<b>5</b>
3.1	Line Rectifier (Dbridge) Selection .....	5
3.2	Input Capacitance ( $C_{IN} = C_{in1} + C_{in2}$ ) Selection .....	6
3.3	Transformer Design.....	7
3.4	Output Capacitor ( $C_{out}$ ).....	12
3.5	Primary Switch Transistor (Q1).....	12
3.6	Resonant Capacitor ( $C_{col}$ ) and $C_p$ Capacitor Selection.....	13
3.7	Output Diode ( $D_{out}$ ) Selection .....	14
3.8	COL Pin Protection ( $D_{col1}$ , $D_{col2}$ and $R_{col}$ ).....	15
3.9	Current Sense Resistors ( $R_2$ and $R_{cs}$ ).....	15
3.10	AUX Pin Supply Resistor ( $R_{aux}$ ) and Transistor ( $Q_{aux}$ ) .....	16
3.11	$V_{DD}$ Feed Resistor ( $R_{dd}$ ).....	16
3.12	Other Components.....	17
<b>4</b>	<b>TESTING AND TROUBLESHOOTING YOUR DESIGN</b> .....	<b>18</b>
4.1	Safety .....	18
4.2	Typical RDFC IV Characteristic .....	18
4.3	First Power-up (No Load) – Standby Mode .....	19
4.4	Running with $P_{OUT}$ at About 25% of Rated Power .....	20
4.5	$P_{OUT}$ Up to Rated Power – Continuous Normal Mode .....	21
4.6	$P_{OUT}$ Above Rated Power - Overload Mode.....	22
4.7	Short Circuit Load - Foldback Mode.....	23
<b>5</b>	<b>EXAMPLE APPLICATION DESIGN</b> .....	<b>24</b>
5.1	Application Design Parameters.....	24
5.2	Components Selected Using The Design Guide .....	25
5.3	Measured Performance.....	26
5.4	Example Design - Circuit Schematic.....	27
5.5	Line-Frequency Ripple .....	28
5.6	Switching-Frequency Ripple .....	28
5.7	Efficiency .....	29
5.8	Load Pull-Up.....	29
5.9	Recovery from Short Circuit.....	30
5.10	Load Transient ( $I_{OUT}$ Step From 10 mA to $I_{NOM}$ ) With Max Load Capacitance.....	30
5.11	Load Transient ( $I_{OUT}$ Step From $I_{NOM}$ to 10 mA) With Max Load Capacitance.....	31
5.12	Turn-on Delay With Max Load Capacitance .....	31
5.13	Operating Frequency (Plot of Q1 Collector Voltage) Measured in Normal Mode.....	32
5.14	Conducted Emissions (EN55022 Class B Quasi Peak Limit) Pre-Compliance Test.....	32
<b>6</b>	<b>REFERENCES</b> .....	<b>33</b>
<b>APPENDIX A DESIGN WORKSHEET</b> .....		<b>33</b>
A.1	Safety .....	33
A.2	Specify Your Design Parameters.....	33
A.3	Select Components Using the Design Guide.....	34
A.4	Measure the Performance of Your Design.....	35

### 1 COMPONENTS IN A TYPICAL RDFC APPLICATION DESIGN

Table 1 lists the components in a typical RDFC application circuit. Some values and types are fixed for designs that can be created with this guide. Others will be determined by working through the guide (in the sections referenced in the “Type / Value” column).

Component	Description	Function	Type / Value
RDFC IC	RDFC controller IC	Resonant forward mode converter controller	C2472PX2 SOT23-6 C2473PX1 SOP-8
Dbridge	Full wave bridge rectifier	Full wave rectification of the ac input voltage	See section 3.1
Cin1, Cin2	Input bulk capacitors	Reduction of line frequency ripple and differential mode EMI (by virtue of the pi filter behaviour)	See section 3.2
Lfilt	Inductor	Input filter – reduces differential mode EMI	See section 3.12
Transformer core		Isolation and forward mode voltage conversion	Section 3.3.1
Secondary turns & wire size			Sections 3.3.2 & 3.3.5
Primary turns & wire size			Sections 3.3.3 & 3.3.6
Auxiliary turns & wire size			Sec. 3.3.4 & 3.3.8
Leakage inductance			See section 3.3.7
Construction			See section 3.3.8
Cout	Output capacitor	Output voltage smoothing	See section 3.4
Q1	Primary Switch transistor	Primary power switch controlled by RDFC IC	See section 3.5
Ccol	Q1 collector coupling capacitor	Sets resonant frequency and senses Q1 collector voltage (used by RDFC control algorithm)	See section 3.6
Cp	Programming capacitor	Sets the Q1 collector saturation voltage threshold	
Dout	Output rectifier	Secondary voltage rectification	See section 3.7
Dcol1, Dcol2	COL protection diodes	Protects COL pin from over-voltage transients	See section 3.8
Rcol	COL protection resistor	Protects COL pin from over-current transients	See section 3.8
Rcs	Current sense resistor	Sets overload protection threshold	See section 3.9
R2	OCPL programming resistor	Controls RDFC converter efficiency at low loads	See section 3.9
Raux	Base drive control resistor	Controls peak Q1 base drive current	See section 3.10
Qaux	AUX bypass transistor	Reduces standby power in high power applications	
Rdd	VDD supply resistor	Limits the VDD current through auxiliary winding	See section 3.11
Fuse	Flameproof fusible resistor or fuse	Provides protection against circuit failure, limits inrush current and aids with surge immunity	See section 3.12
V1	Input varistor	May be needed to meet full surge requirements	See section 3.12
Rntc	NTC thermistor	Limits inrush current	See section 3.12
Rht1, Rht2	VDD supply resistors	Supplies VDD during Start-up mode.	See section 3.12
Csnub	Snubber capacitor	To reduce EMI during output diode turn-off	See section 3.12
Rsnub	Snubber resistor	To reduce EMI during output diode turn-off	See section 3.12
Rout	Output bleed resistor	Limits output voltage rise with no load and provides a discharge path for Cout when VIN is turned off	See section 3.12
Cdd	Ceramic VDD capacitor	Decouples the chip VDD supply	See section 3.12
Daux	Auxiliary rectifier	Rectifies auxiliary voltage	See section 3.12
Caux	Auxiliary capacitor	Decouples the chip AUX supply	See section 3.12

Table 1: RDFC Application Circuit Components

### 2 APPLICATION DESIGN PARAMETERS

Table 2 lists key RDFC application design parameters. It provides an indication of the performance achievable with the RDFC topology in general and, in particular, when using this design guide. Design parameters that are specified by the user when using this guide are shown as “User-defined”.

Design Parameter	Symbol	Typical Range Achievable with RDFC	Typical Value Using this Design Guide	Comments
Input voltage	$V_{IN}$	115 Vac (98 to 132 Vac) 230 Vac (196 to 265 Vac)	User-defined	Application designs are specified for $\pm 15\%$ of the nominal input voltage
Nominal rated output power	$P_{NOM}$	6 W to 40 W	User-defined	RDFC chip is rated for applications in this power range
Nominal output voltage	$V_{NOM}$	5 V to 24 V	User-defined	
Nominal output current	$I_{NOM}$	0.25 A to 3 A	$P_{NOM} / V_{NOM}$	Constrains the allowable combination of $P_{NOM}$ and $V_{NOM}$
Average efficiency	$\eta$	77 % to 92 %	80 %	Low power, low output voltage applications will be less efficient
Load regulation	-	10 % to 30 % of $V_{NOM}$	15%	Low-leakage transformers, and high value input capacitors give better load regulation
No load power consumption	$P_{STBY}$	100 mW – 250 mW	150 mW	Range of standby power dissipation measured with actual designs
Output ripple (line input related)	-	3 % to 20 % of $V_{NOM}$ peak to peak	5% (230 Vac) 10% (115 Vac)	Application-dependent. Occurs at twice the line frequency when using full-wave input rectification.
Output ripple (switching related)	-	1 % to 5 % of $V_{NOM}$ peak to peak	2.5%	Application-dependent. Occurs at the switching frequency.
Load pull-up capability	-	Capable of pulling-up constant voltage, constant current, constant resistance and constant power loads	Constant resistance	High leakage transformers make it easier to pull-up constant current or constant power loads
Maximum load capacitance	$C_{LOAD}$	6000 $\mu F$	1000 $\mu F$	Smaller load capacitance is easier for load pull-up. Larger load capacitance may reduce maximum output current
Operating frequency of the converter	F	40 kHz to 60 kHz	50 kHz	Component value adjustments may be required to achieve the target operating frequency.
Conducted emissions EN55022 class B	-	Compliant with margin	Compliant with 6 dB margin	Requires careful transformer design for high power applications

Table 2: RDFC Application Design Parameters

### 3 COMPONENT SELECTION

Note: Lookup tables in this design guide may not have an exact match for a parameter value required in your target application. In such cases, look up the lowest value greater than that which applies to your design. For example, if your chosen nominal rated power ( $P_{NOM}$ ) is 14 W, look up 15 W in the tables.

#### 3.1 Line Rectifier (Dbridge) Selection

The input line rectifier can be implemented with four discrete diodes or an integrated bridge rectifier depending on the power requirement, cost and PCB area available for the application. Use Table 3 to select a suitable type based on the nominal rated power ( $P_{NOM}$ ) of your design and the expected maximum forward current in the bridge. Choose the row with the lowest value of  $P_{NOM}$  greater than the rated power of your design. The shaded grey cell indicates the components suitable for the design example in section 5 (page 24). Note: the minimum recommended repetitive reverse voltage rating ( $V_{RRM}$ ) of the diodes in the bridge is 300 V for 115 Vac applications and 600 V for 230 Vac applications.

Nominal Power Rating $P_{NOM}$ (W)	$I_{IN}$ (mA) (at 80% efficiency)		Input Rectifier Type	
	$V_{IN} = 115$ Vac	$V_{IN} = 230$ Vac	$V_{IN} = 115$ Vac	230 Vac
6	54	27	4 x 1N4007	4 x 1N4007
9	81	41	4 x 1N4007	4 x 1N4007
12	109	54	4 x 1N4007	4 x 1N4007
15	136	68	2KBB60RPBF	KBP206G
18	163	81	2KBB60RPBF	KBP206G
20	181	90	2KBB60RPBF	KBP206G
25	226	113	2KBB60RPBF	KBP206G
30	271	136	2KBB60RPBF	KBP206G
35	316	158	2KBB60RPBF	KBP206G
40	362	181	2KBB60RPBF	KBP206G

Table 3: Input Rectifier Selection

### 3.2 Input Capacitance ( $C_{IN} = C_{in1} + C_{in2}$ ) Selection

The typical RDFC application circuit in Figure 1 on page 1 assumes the use of two parallel input capacitors ( $C_{in1}$  and  $C_{in2}$ ) to achieve the total input capacitance required ( $C_{IN}$ ). The value of  $C_{IN}$  required depends on the average primary current and peak-to-peak ripple voltage at the input capacitance for a given target output ripple. The total input capacitance values ( $C_{IN}$ ) in Table 4 are suitable for 10% and 5% line-related ripple at 115 Vac and 230 Vac respectively and average efficiency of 80%. Note: electrolytic capacitor voltage ratings should be no less than: 200 Vdc for 115 Vac applications and 400 Vdc for 230 Vac applications. The shaded grey cell in Table 4 is the input capacitance value ( $C_{IN}$ ) suitable for the design example in section 5 (page 24).

Nominal Power Rating $P_{NOM}$ (W)	$C_{IN} = C_{in1} + C_{in2}$ ( $\mu F$ )	
	$V_{IN} = 115$ Vac (10% ripple)	$V_{IN} = 230$ Vac (5% ripple)
6	28	17
9	43	26
12	57	34
15	71	43
18	85	51
20	95	57
25	120	71
30	140	85
35	170	100
40	190	110

Table 4: Input Capacitance ( $C_{IN} = C_{in1} + C_{in2}$ ) Requirement

You can scale the input capacitance value for a different percentage line-frequency ripple requirement using the following equations:

$$C_{IN-SCALED} = C_{IN} \times 10 / \text{ripple} \quad (\text{for } 115 \text{ Vac applications})$$

$$C_{IN-SCALED} = C_{IN} \times 5 / \text{ripple} \quad (\text{for } 230 \text{ Vac applications})$$

Where  $C_{IN}$  is the total input capacitance from Table 4;  
 ripple is the revised ripple requirement (as a % of  $V_{NOM}$ )  
 $C_{IN-SCALED}$  is the input capacitance scaled for a different line-frequency ripple voltage requirement;

For example, the input capacitance value for 20% line-frequency ripple in a 35 W, 115 Vac application will be

$$C_{IN-SCALED} = 170 \times 10 / 20 \quad (\text{the unscaled } C_{IN} \text{ value of } 170 \mu F \text{ is from Table 4})$$

$$\approx 85 \mu F$$

### 3.3 Transformer Design

Design of RDFC transformers is key for achieving optimum performance. The type, size and construction of the transformer is based on the nominal rated power output ( $P_{NOM}$ ), type of load, input voltage, size of the power supply and target cost. RDFC transformers have three functional windings: primary, secondary and auxiliary.

#### 3.3.1 Core Size Selection

Choice of core size depends on the application requirements for cost, power rating, leakage inductance and EMC performance. Table 5 gives recommended sizes for typical applications based on nominal rated power. The recommendations assume use of low-loss core material suitable for 50 kHz operation, e.g. 3C90. The shaded grey cell in Table 5 contains the core type recommended for the design example on page 24.

Nominal Power Rating $P_{NOM}$ (W)	Recommended Core size
6	E16/8/5
9	E16/8/5
12	E19/8/5
15	E20/10/6
18	E20/10/6
20	E20/10/6
25	E20/10/6
30	E25/13/7
35	E25/13/7
40	E25/13/7

Table 5: Core Size Selection Table

#### 3.3.2 Number of Secondary Turns ( $N_S$ )

Table 6 gives the fractional number of secondary turns ( $N_{SPV}$ ) required per volt on the anode of the output diode (Dout). The actual number of secondary turns ( $N_S$ ) required is given by  $N_S = N_{SPV} \times (V_{NOM} + V_{DOUT})$ , where  $V_{DOUT}$  is the nominal voltage drop across Dout. The shaded grey cell is value of  $N_{SPV}$  for the design example on page 24.

Core Size	E16	E19	E20	E25
$N_S$	1.36	1.13	0.81	0.50

Table 6: Fractional Number of Secondary Turns Required per Output Volt ( $N_{SPV}$ )

Note:  $N_S$  must be rounded up to the nearest whole number. For example, in a 115 Vac, 15 W, 9 V application, recommended core is E20 (from Table 5) so the number of secondary turns per output volt (from Table 6) is 0.81. The actual number of secondary turns to use is then given by:

$$N_S = N_{SPV} \times (V_{NOM} + V_{DOUT})$$

$$N_S = 0.81 \times (9 + 0.5) = 7.7 \quad (\text{assuming } V_{DOUT} \approx 0.5 \text{ V})$$

$$N_S = 8 \quad (\text{rounded up to nearest whole number})$$

Rounding up the number of secondary turns means that the number of turns on the primary and secondary windings must be scaled up in order to preserve the correct turns ratio. The simple calculation is explained in the following sections.

### 3.3.3 Number of Primary Turns ( $N_P$ )

The typical number of primary turns  $N_{PTYP}$  for a given input voltage ( $V_{IN}$ ) and core size is shown in Table 7. These numbers are consistent with fully resonant operation, core flux swing from -60% to 100%, maximum flux density ( $B_{MAX}$ ) of 300 mT, maximum input voltage and 10% allowance for design margin. The shaded grey cell is the typical number of primary turns for the design example on page 24.

Core Size	E16	E19	E20	E25
$V_{IN}$ 115 Vac	191	159	114	70
$V_{IN}$ 230 Vac	384	321	230	142

Table 7: Typical Number of Primary Turns ( $N_{PTYP}$ )

To maintain the correct turns ratio the number of primary turns must be scaled to account for the amount by which the number of secondary turns was rounded up (see section 3.3.2):

$$N_P = N_{PTYP} \times N_S \text{ (after rounding)} / N_S \text{ (before rounding)}$$

For example, in a 115 Vac, 15 W, 9 V application,  $N_P$  from Table 7 is 114. Using the rounded and unrounded number of secondary turns for that application (see section 3.3.2) the required number of primary turns is:

$$N_P = 114 \times 8 / 7.7$$

$$N_P = 119 \quad \text{(rounded to the nearest whole number)}$$

### 3.3.4 Number of Auxiliary Turns ( $N_{AUX}$ )

The minimum number of auxiliary turns ( $N_{AUXMIN}$ ) required for a given core size is shown in Table 8. The shaded grey cell is the number to choose for the design example in section 5 (page 24).

Core Size	E16	E19	E20	E25
$N_{AUXMIN}$	12	10	7	5

Table 8: Minimum Number of Auxiliary Turns ( $N_{AUXMIN}$ )

To maintain the correct turns ratio the number of auxiliary turns must be scaled (just like the number of primary turns) to account for the amount by which the number of secondary turns was rounded up (in section 3.3.2):

$$N_{AUX} = N_{AUXMIN} \times N_S \text{ (after rounding)} / N_S \text{ (before rounding)}$$

In the 115 Vac, 15 W, 9 V application,  $N_{AUXMIN}$  from Table 8 is 7. Using the rounded and unrounded number of secondary turns for that application (see section 3.3.2) the required number of auxiliary turns is:

$$N_{AUX} = 7 \times 8 / 7.7$$

$$N_{AUX} = 7 \quad \text{(rounded to the nearest whole number)}$$

### 3.3.5 Secondary Winding Conductor Size

Use Table 9 to select a suitable conductor size for the secondary winding wire. Note that for some combinations of nominal rated power and voltage the windings must be bifilar or multilayer. Where no conductor size is recommended it is because the design rating is outside the range that can be created using this guide. The shaded grey cell contains the conductor size selected for the design example in section 5 (page 24).

Nominal Rated Power $P_{NOM}$ (W)	Nominal Output Voltage $V_{NOM}$ (V dc)							
	5	6	9	12	15	18	21	24
6	0.6	0.45	0.25	0.2 M	0.2 M	0.2 M	0.2 M	0.2 M
9	0.6	0.45	0.25	0.2 M	0.2 M	0.2 M	0.2 M	0.2 M
12	1.0	0.9	0.5	0.35	0.25	0.2 M	0.2 M	0.2 M
15	0.7 B	0.5 B	0.8	0.6	0.45	0.35	0.25	0.2
18	-	0.5 B	0.8	0.6	0.45	0.35	0.25	0.2
20	-	-	0.8	0.6	0.45	0.35	0.25	0.2
25	-	-	0.8	0.6	0.45	0.35	0.25	0.2
30	-	-	-	0.6 B	1.0	0.9	0.8	0.6
35	-	-	-	0.6 B	1.0	0.9	0.8	0.6
40	-	-	-	-	1.0	0.9	0.8	0.6

Table 9: Secondary Wire Conductor Diameter (mm) B = Bifilar, M = Multilayer

### 3.3.6 Primary Winding Conductor Size

Use Table 10 to select a suitable conductor size for the primary winding wire, based on nominal rated power of the application. The shaded grey cell contains the conductor size selected for the design example in section 5 (page 24).

Nominal Power Rating $P_{NOM}$ (W)	$V_{IN} = 115$ Vac	$V_{IN} = 230$ Vac
6	0.16	0.1
9	0.16	0.1
12	0.2	0.16
15	0.25	0.16
18	0.25	0.16
20	0.25	0.16
25	0.25	0.16
30	0.3	0.2
35	0.3	0.2
40	0.3	0.2

Table 10: Primary Winding Wire Conductor Diameter (mm)

The transformers presented in this guide have been designed to operate in an open frame convection cooled environment with a maximum ambient air temperature of 40 °C. Products that must operate with a higher ambient air temperature, including enclosed products such as plug top adapters, require transformer designs with a lower power loss. Please contact CamSemi for advice on designing transformers for these applications.

### 3.3.7 Transformer Inductances

The transformer primary inductance (measured at 50 kHz with the secondary and auxiliary windings open circuit) should be approximately as shown in Table 11.

Core Size	E16	E19	E20	E25
$V_{IN} = 115 \text{ Vac}$	40	30	19	9
$V_{IN} = 230 \text{ Vac}$	46**	32**	28**	38

Table 11: Typical Primary Winding Inductance (mH)

\*\*Transformer cores gapped in the range 50 -100  $\mu\text{m}$  are required for most 230 Vac applications to avoid core saturation. Table 11 shows typical primary winding inductance values for 230 Vac applications with E16, E19 and E20 cores gapped to approximately 70  $\mu\text{m}$ .

Typical leakage inductance values are in the range 150  $\mu\text{H}$  to 300  $\mu\text{H}$  for 115 Vac applications and 200  $\mu\text{H}$  to 500  $\mu\text{H}$  for 230 Vac applications. Measure leakage inductance with the secondary and auxiliary windings shorted. Note that high leakage inductance may be required for good load start-up, which may conflict with the load regulation requirement.

### 3.3.8 Transformer Construction

Figure 2 shows the construction of a typical, low-leakage inductance RDFC transformer. Note the location of the dots indicating the relative phases of the primary and secondary windings – they reflect the fact that this transformer is for a forward topology, not a flyback. The auxiliary winding provides power to the controller IC during normal operation. A screen is placed between the primary and secondary to reduce noise coupling.

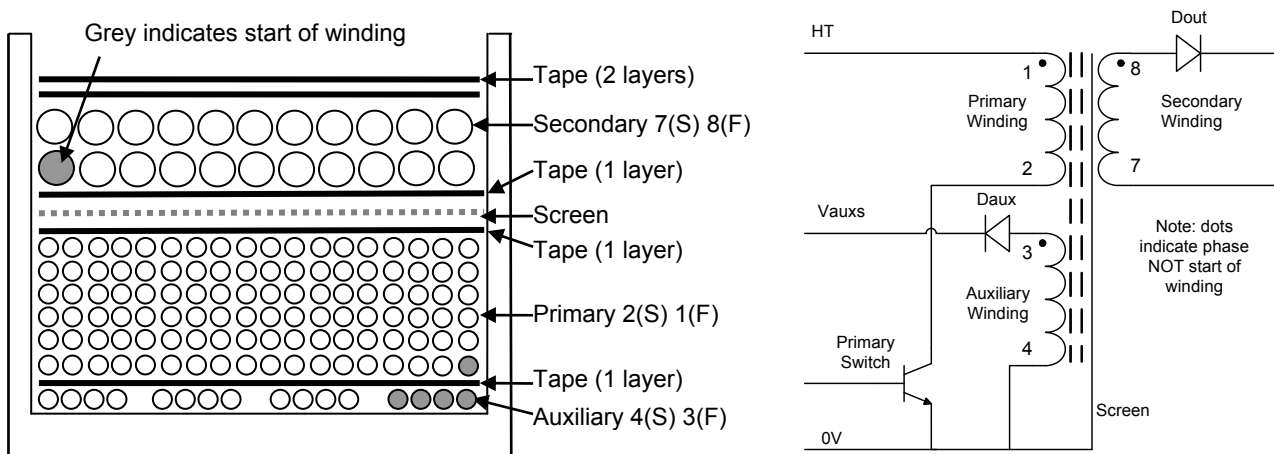

Figure 2: Transformer Cross Section and Schematic  
 Note: s(S) means start on pin s, f(F) means finish on pin f

Transformer construction can be varied to meet EMC targets and optimise leakage inductance according to particular application requirements. Table 12 summarises instructions for winding a typical low-leakage RDFC transformer.

Winding	Wire	Layers	Comments
Auxiliary	Grade 2 enamelled copper wire. 0.2 mm diameter conductor.	1	Full width neatly wound. Use optimum number of multi-filar windings to cover the bobbin width. After termination to the pins, put a small piece of tape on the inside of the bobbin, covering the winding lead-outs.
Tape	Class B Polyester film	1	Full width with a small overlap at the ends.
Primary	Grade 2 enamelled copper wire. Refer to Table 10 for conductor diameter.	Multiple	Full width neatly wound layers. After termination to the pins, put a small piece of tape on the inside of the bobbin covering the winding lead-outs.
Tape	Class B polyester film	1	Full width with a small overlap at the ends.
Screen	Copper foil or grade 2 enamelled copper wire.	1	Cover the full width of the bobbin. Connect to 0 V (pin 4) of the bobbin (see Figure 2). A method for implementation of wound screens is described in the patent JP60226112 (Hitachi Ltd, Nippon Telegraph and Telephone, 1985)
Tape	Class B polyester film	1	Full width with a small overlap at the ends.
Secondary	Triple insulated wire (Furukawa TEX-E). Refer to Table 9 for conductor diameter.	1 or 2	Use flying leads with E13, E16, E19 or E20 cores. Start at the top of the bobbin, against the wall on the side near to the secondary side of the PCB. Mark the start with a sleeve. Avoid placing the wire hard up against the wall on the primary side of the PCB.
Tape	Class B polyester film	2	Full width with a small overlap at the ends.

Table 12: Winding a Low-leakage Transformer for a Typical RDFC Application

Note also:

- Care should be taken to avoid crossing the start and finish ends of windings near the pins;
- Minimise the separation between primary and secondary in order to achieve low-leakage inductance;
- Secure the cores with glue or tape so that the faces are in firm contact;
- Wrap the core with three complete layers of polyester, tape wider than the core;
- Varnish-dip. Avoid getting varnish on the pins. Vacuum impregnation is not recommended because it increases capacitances between the windings which can increase levels of conducted EMI.

### 3.4 Output Capacitor (Cout)

The output capacitor (Cout) is selected according to requirements for ripple current rating, effective series resistance (ESR), size and cost. Table 13 shows the minimum ripple current rating and maximum ESR for Cout for a given nominal output current (I<sub>NOM</sub>), assuming a low leakage transformer design and peak-to-peak switching ripple voltage of 150 mV. The shaded grey cells are the ratings chosen for the design example in section 5 (page 24).

I <sub>NOM</sub> = P <sub>NOM</sub> / V <sub>NOM</sub> (A)	Ripple Current (A rms)	ESR Max (mΩ)
0.25	0.28	170
0.5	0.56	86
0.75	0.84	57
1	1.1	43
1.25	1.4	34
1.5	1.7	29
1.75	2.0	24
2	2.2	21
2.25	2.5	19
2.5	2.8	17
2.75	3.0	16
3	3.4	14

Table 13: Output Capacitor (Cout) Rating

The recommended minimum dc voltage rating for Cout is 1.25 x V<sub>NOM</sub>.

### 3.5 Primary Switch Transistor (Q1)

Selection of the primary switch transistor (Q1) should take in to account the following factors:

- The maximum collector voltage (V<sub>CE</sub>) it must withstand under all possible operating conditions;
- The maximum collector current (I<sub>C</sub>) before over current protection (OCP) comes into effect;
- The worst case voltage and current stress it has to withstand during turn off;
- The minimum H<sub>FE</sub> required, which is determined by the base drive capability of the RDFC controller.

Table 14 lists transistor types suitable for use as the primary switch in RDFC applications. The shaded grey cells indicate the type chosen for the design example in section 5 (page 24).

Nominal Power Rating $P_{NOM}$ (W)	$V_{IN} = 115$ Vac		$V_{IN} = 230$ Vac	
	Q1 Type	Package	Q1 Type	Package
6	MJE13003	TO-92	TT2274A	TO-126
9	MJE13003	TO-126	TT2274A	TO-126
12	MJE13003	TO-126	TT2274A	TO-126
15	MJE13003	TO-126	TT2274A	TO-126
18	MJE13005	TO-220	TT2274A	TO-126
20	MJE13005	TO-220	2SC6084 or 3DD5023	TO-220
25	TS13007B	TO-220	2SC6084 or 3DD5023	TO-220
30	TS13007B	TO-220	2SC6084 or 3DD5023	TO-220
35	TS13007B	TO-220	2SC6084 or 3DD5023	TO-220
40	TS13007B	TO-220	2SC6084 or 3DD5023	TO-220

Table 14: Transistor Types Suitable for Use as the Primary Switch (Q1)

Voltage rating requirements of the primary switch are:

$$\begin{aligned}
 230 \text{ Vac operation:} & \quad V_{cbo} \geq 1200 \text{ V}, \quad V_{ceo} \geq 700 \text{ V} \\
 115 \text{ Vac operation:} & \quad V_{cbo} \geq 700 \text{ V}, \quad V_{ceo} \geq 400 \text{ V}
 \end{aligned}$$

Notes:

1. The  $V_{cbo}$  rating of 1200 V is a minimum realistic rating for 230 Vac applications. Power supplies should be carefully characterised for peak off-state  $V_{ce}$  under worst case operating conditions. A  $V_{cbo}$  rating of 1400 V may be required in some designs to give adequate operating margin. See document reference AN-2274 “Key RDFC Application Circuit Measurements”, available at [www.camsemi.com](http://www.camsemi.com), for guidance on characterizing an RDFC design in this and other respects. Also, refer to document reference AN-2276 “Power BJT Specification for RDFC Applications”, available at [www.camsemi.com](http://www.camsemi.com), for further information about specifying BJTs for RDFC applications. Manufacturers’ datasheets should be consulted to ensure suitability of the particular component chosen for Q1.
2. Characteristics of the primary switch can have an effect on various aspects of application performance. For example, no-load power consumption and active efficiency. Thorough testing is recommended to ensure that the chosen of transistor is suitable for all application requirements.
3. In some applications (particularly those with a rated power of 18 W or more) heat-sinking of the transistor may be required to avoid excessive rise in temperature.

### 3.6 Resonant Capacitor ( $C_{col}$ ) and $C_p$ Capacitor Selection

The resonant capacitor ( $C_{col}$ ) is situated between the primary switch collector and the RDFC controller COL pin. Table 15 gives the recommended values of  $C_{col}$  for different core types assuming 50 kHz operating frequency, the number of primary turns specified in Table 7, a screen between primary and secondary and 3C90 core material. When selecting  $C_{col}$ , avoid dielectric material with ageing characteristics and high dielectric absorption with applied voltage or temperature. **Class 1 ceramic material such as C0G (NP0) is strongly required.**  $C_{col}$  must be a high voltage type: 1 kVdc for 115 Vac applications and 1.5 kVdc for 230 Vac applications. The shaded grey cell in Table 15 indicates the value chosen for the design example in section 5 (page 24).

The  $C_p$  capacitor allows the Q1 on-state collector voltage to be optimised depending on the transistor type and input voltage. For 115 Vac applications using 700 V  $V_{cbo}$  rated transistors on-state threshold voltage should be set in the range 2 V to 3 V typically. For 230 Vac applications using 1200-1500 V  $V_{cbo}$  rated

transistors on-state threshold voltage should be set in the range 4 V to 6 V typically. However the optimum on-state threshold voltage can vary depending on the transistor product and nominal power rating of the power supply. Table 15 provides recommended Cp values for different core types and input voltages. Cp capacitor only needs a dc rating of 50 V.

Core Size	Ccol (pF)		Cp (pF)	
	V <sub>IN</sub> = 115 Vac	V <sub>IN</sub> = 230 Vac	V <sub>IN</sub> = 115 Vac	V <sub>IN</sub> = 230 Vac
E16	82	47	47	150
E19	100	47	68	150
E20	120	47	82	150
E25	150	47	100	150

Table 15: Resonant Capacitor (Ccol) and Cp Values

### 3.7 Output Diode (Dout) Selection

The output diode (Dout) must withstand continuous operation under overload conditions and reverse voltage at peak input voltage. For efficiency reasons, Schottky diodes should be used for output voltages (V<sub>NOM</sub>) up to 12 V. Above that level fast epitaxial diodes are suitable. In Table 16 V<sub>RRMIN</sub> is the minimum recommended reverse voltage rating (V<sub>RRM</sub>) for Dout and I<sub>F(AV)</sub> is the minimum recommended average forward current handling capability. Select an output diode from Table 16 based on application rated output current (I<sub>NOM</sub>). Where no diode type is recommended it is because the design rating is outside the range that can be created using this guide. A heat sink may be required on Dout in higher power applications. The shaded grey cell indicates the diode type chosen for the design example in section 5 (page 24).

I <sub>NOM</sub> = P <sub>NOM</sub> / V <sub>NOM</sub> (A)	I <sub>F(AV)</sub> (A)	Application Nominal Output Voltage (V <sub>NOM</sub> )							
		5 V	6 V	9 V	12 V	15 V	18 V	21 V	24 V
0.25	0.38	-	-	-	-	-	-	-	BYV27-200
0.5	0.75	-	-	-	SB160	SF12G	SF12G	BYV27-200	BYV27-200
0.75	1.13	-	-	STPS2L60	STPS2L60	SF32G	SF32G	BYV27-200	BYV27-200
1.0	1.50	-	1N5822	STPS2L60	STPS2L60	SF32G	SF32G	BYV27-200	BYV27-200
1.25	1.88	1N5822	1N5822	SB360	SB360	SF32G	SF32G	BYV27-200	BYV27-200
1.5	2.25	1N5822	1N5822	SB360	SB360	SF32G	SF32G	BYV28-200	BYV28-200
1.75	2.63	1N5822	1N5822	SB360	SB360	SF32G	SF32G	BYV28-200	-
2.0	3.00	SB540	SB540	SB560	SB560	SF62	SF62	-	-
2.25	3.38	SB540	SB540	SB560	SB560	SF62	-	-	-
2.5	3.75	SB1040	SB1040	SB1060	SB1060	SF62	-	-	-
2.75	4.13	SB1040	SB1040	SB1060	SB1060	-	-	-	-
3.0	4.50	SB1040	SB1040	SB1060	SB1060	-	-	-	-
<b>Dout V<sub>RRMIN</sub> rating</b>		26 V	30 V	45 V	59 V	73 V	88 V	102 V	116 V

Table 16: Output Diode (D<sub>OUT</sub>) Selection

### 3.8 COL Pin Protection (Dcol1, Dcol2 and Rcol)

Diodes Dcol1, Dcol2 and resistor Rcol (see Figure 3) protect the controller COL pin from voltage and current excursions. 1N4148 or any other fast recovery diode with at least 0.2 A forward current capability is suitable for Dcol1 and Dcol2. Schottky diodes should not be used because their leakage current may be too high. The value of Rcol should be a 220  $\Omega$ .

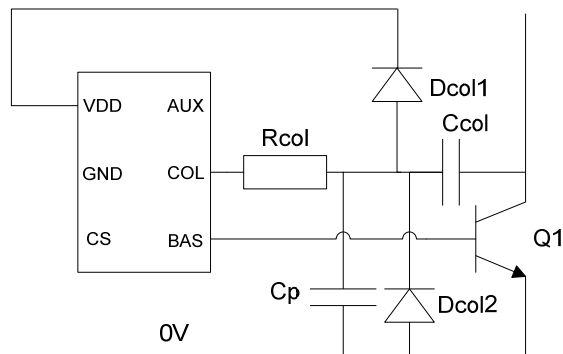

Figure 3: COL pin protection circuit

### 3.9 Current Sense Resistors (R2 and Rcs)

The RDFC controller has two internal threshold values called OCPH (overcurrent protection high) and OCPL (overcurrent protection low) which are set by two external resistors, R2 and Rcs (see Figure 4). OCPH sets the point at which the controller will limit output current and ultimately go into Foldback mode (overload protection). OCPL is used to optimise switching duty cycle for converter efficiency at low loads. Refer to the RDFC controller datasheet (DS-1423) for further information.

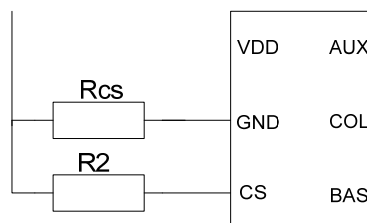

Figure 4: OCPH and OCPL Programming Circuit

The value of R2 is typically 470  $\Omega$  but must be adjusted to suit a particular application (see section 4.7). Table 17 gives recommended Rcs values and power ratings for given mains input voltage ( $V_{IN}$ ) and nominal rated power ( $P_{NOM}$ ). The shaded grey cell indicates the value and power rating of Rcs chosen for the design example in section 5 (page 24).

Nominal Power Rating $P_{NOM}$ (W)	115 Vac		230 Vac	
	$\Omega$	W	$\Omega$	W
6	1.18	0.125	2.34	0.125
9	0.78	0.125	1.56	0.125
12	0.59	0.25	1.17	0.125
15	0.47	0.25	0.94	0.125
18	0.39	0.25	0.78	0.125
20	0.35	0.5	0.70	0.5
25	0.28	0.5	0.56	0.5
30	0.24	0.5	0.47	0.5
35	0.20	0.5	0.40	0.5
40	0.18	1.0	0.35	0.5

Table 17: Rcs Resistor Selection

### 3.10 AUX Pin Supply Resistor ( $R_{aux}$ ) and Transistor ( $Q_{aux}$ )

Base drive current for the primary switch (Q1) is supplied via the AUX pin of the controller. Table 18 gives recommended values of  $R_{aux}$  according to application nominal rated power ( $P_{NOM}$ ). The shaded grey cell indicates the value of  $R_{aux}$  for the design example in section 5 (page 24). For  $Q_{aux}$  use a BC337-40 or similar high gain transistor.

Nominal Power Rating $P_{NOM}$ (W)	$R_{aux}$ ( $\Omega$ )
6	56
9	12
12	12
15	12
18	12
20	12
25	12
30	12
35	12
40	12

Table 18:  $R_{aux}$  Resistor Value Selection

### 3.11 $V_{DD}$ Feed Resistor ( $R_{dd}$ )

A  $V_{DD}$  feed resistor is required that will provide sufficient supply current to the chip (via the VDD pin) at minimum auxiliary winding voltage (about 6 V) but which dissipates minimum power itself (to limit design standby power). For applications in the range 6 W to 40 W a value of 1 k $\Omega$  should be sufficient. It is important to check the auxiliary rectified supply voltage at  $C_{AUX}$  under all load conditions (especially in short circuit at low mains input voltage) to ensure sufficient current to maintain Vdd supply.

### 3.12 Other Components

Refer to Table 19 for selection of components not covered in preceding sections.

Component	Description	Notes
Lfilt	Input filter inductor	Reduces differential mode EMI. Value depends on $P_{NOM}$ . $P_{NOM} < 15\text{ W}$ : 1 mH $P_{NOM} \geq 15\text{ W}$ : 330 $\mu\text{H}$
Fuse	Flameproof fuse or fusible resistor	Provides protection in the event of failure in the converter circuit. Also (if a resistor) limits inrush current and assists with surge immunity.
V1	Input varistor	May be needed to meet surge requirements, if the resistance of the input Fuse/resistor is insufficient.
Rntc	NTC thermistor	Limits inrush current. Typically 10 $\Omega$ .
Rht1, Rht2	VDD supply resistor	Must meet operating voltage and fail safely in case of component failures. Typically two SMT resistors or two flameproof metal oxide leaded resistors (in series to share voltage stress). $V_{IN} = 115\text{ Vac}$ : Rht1 = Rht2 = 2.7 M $\Omega$ total resistance 5.4 M $\Omega$ $V_{IN} = 230\text{ Vac}$ : Rht1 = Rht2 = 4.7 M $\Omega$ total resistance 9.4 M $\Omega$
Csnub	Snubber to reduce EMI from output diode turn-off	A ceramic type, with value typically between 1 nF and 2.2 nF. Voltage rating should be at least equal to the $V_{RRM}$ rating of Dout (see Table 16 in section 3.7). Value may need to be optimised to meet EMC emission limits.
Rsnub	Snubber to reduce EMI from output diode turn-off	Typically 22 $\Omega$ to 100 $\Omega$ . Value may need to be optimised to meet EMC emission limits.
Rout	Output bleed resistor	To limit voltage rise with no load and provide a discharge path when $V_{IN}$ is disconnected. Rout is typically only used in applications requiring tight output regulation from no load to full load. Choose a value of, say, 10 k $\Omega$ /V output. I.e. Rout (k $\Omega$ ) = 10 x $V_{NOM}$ .
Cdd	VDD decoupling capacitor	Decouples the chip VDD supply. A 1 $\mu\text{F}$ , 10V ceramic type is suitable for use as Cdd.
Daux	Auxiliary voltage rectifier	1N4148 is a suitable fast recovery diode for use as Daux.
Caux	AUX decoupling capacitor	Decouples the chip AUX supply rail. A 470 nF, 16 V ceramic type is suitable for use as Caux.

Table 19: Selection of Other Components

### 4 TESTING AND TROUBLESHOOTING YOUR DESIGN

Once the components are selected and the transformer constructed a prototype of the design can be made. This section takes you through a stepwise approach to testing and observing behaviour of your application design. Refer to the RDFC controller datasheet (reference DS-1423) for further information about the ICs and their operating modes.

#### 4.1 Safety

Offline power supplies, particularly in a development situation, can present hazards including, but not limited to, electric shock, high temperatures, fire and smoke. They should be operated and used only by competent, trained personnel. In particular:

- The unit to be tested should be checked for design and build errors before applying mains power;
- The unit under test should be powered via a suitable isolating transformer and a variac;
- Hazardous voltages are present in both normal and abnormal operating conditions;
- Insulation between high voltage and low voltage parts may not provide safety isolation;
- All connections should be regarded as LIVE and HAZARDOUS.

#### 4.2 Typical RDFC IV Characteristic

Figure 5 shows a typical RDFC IV characteristic for designs made with this guide. It is labelled with the names of the various controller operating modes. The following sections describe these modes in more detail with oscilloscope screen images of the primary switch collector voltage that is expected in each.

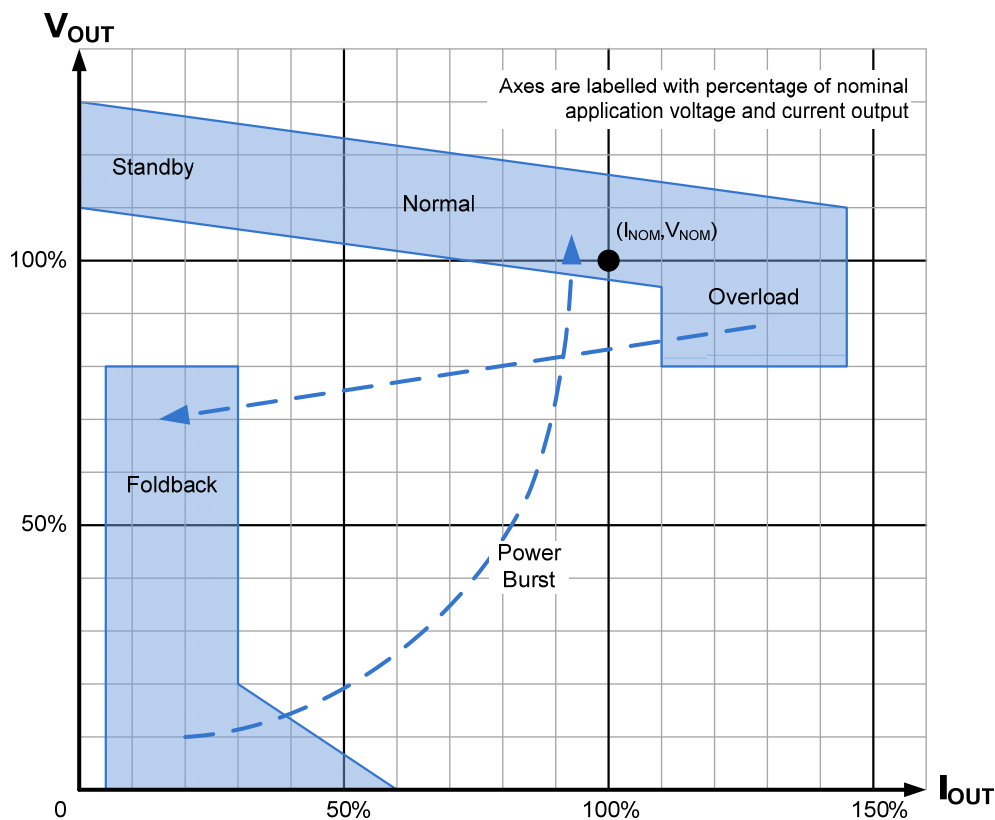

Figure 5: Typical RDFC Power Supply Characteristic Indicating Different Active Modes of Operation

### 4.3 First Power-up (No Load) – Standby Mode

Please read the safety advice in section 4.1 before applying power to any application circuit.

Attach a high voltage oscilloscope probe to the collector of the primary switch (Q1). Apply nominal input voltage (115 Vac or 230 Vac) with no load on the output. Observe the collector voltage waveform. It should be similar to the oscilloscope plot in Figure 6 (note, in Figure 6  $V_{IN} = 115 \text{ Vac}$ ).

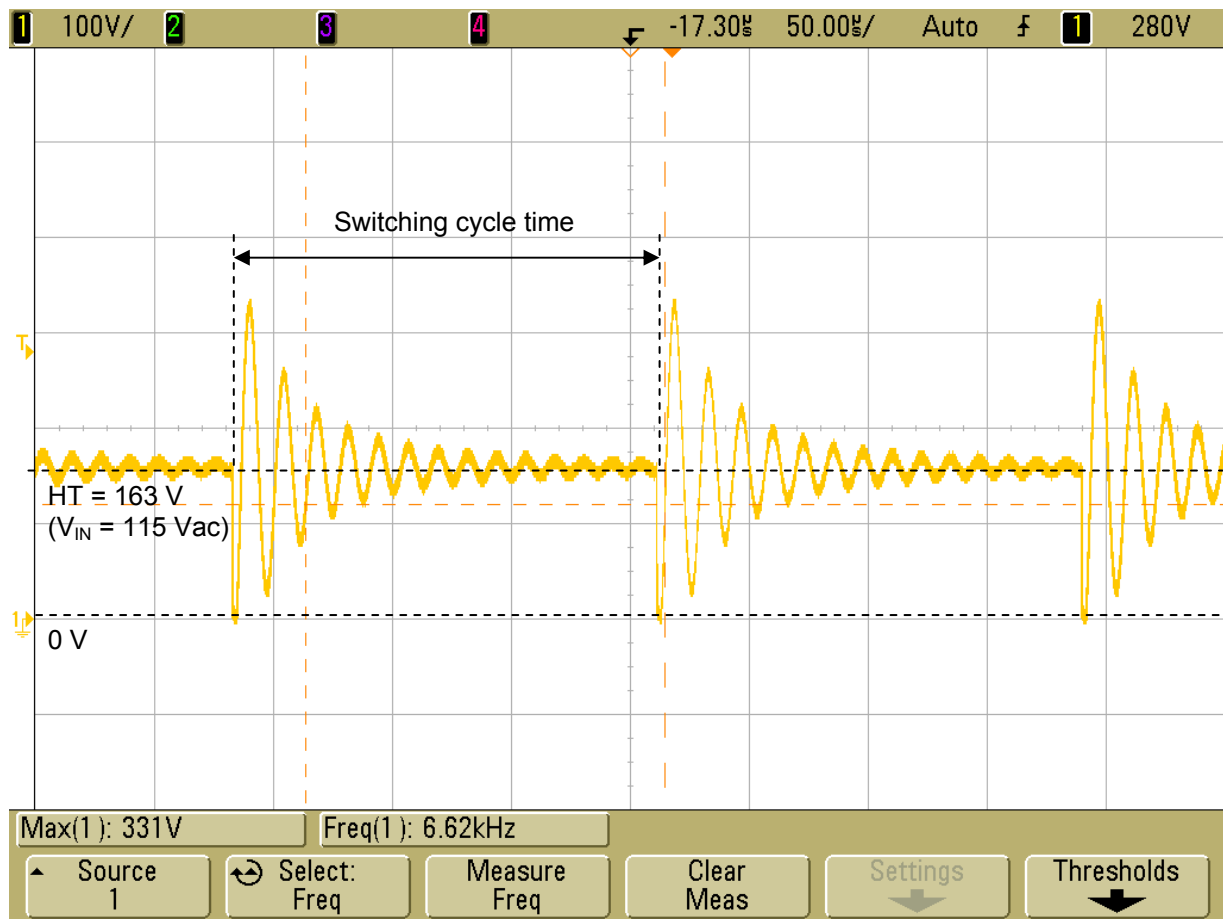

Figure 6: Q1 Collector Voltage Waveform With No Load (Controller in Standby Mode)

- If no switching signal is observed check the primary side components for connectivity and correct polarity;
- If there are only a few switching cycles, say every approximately 10 ms, check the components connected to the auxiliary winding;
- If the switching cycle time of the observed signal (dominated by the Q1 off-time) is below 150  $\mu\text{s}$ , increase the value of R2 in 10% steps until the period is approximately 200  $\mu\text{s}$ . This reduces Standby power consumption.

### 4.4 Running with $P_{OUT}$ at About 25% of Rated Power

Still with minimum input voltage, attach a 25% load to observe an oscilloscope plot similar to the one in Figure 7. It shows the converter changing between Standby and Normal modes – this is expected RDFC behaviour with the load at around 25% of the application rated power. If only Normal mode operation is observed with no changes in and out of Standby (i.e. fully resonant switching and no change in the on-time of switching cycles), increase the value of R2 (in steps of, say, 10%) until the expected waveform is observed. If only standby operation is observed with no change to Normal mode, try reducing the value of R2, again in 10% steps.

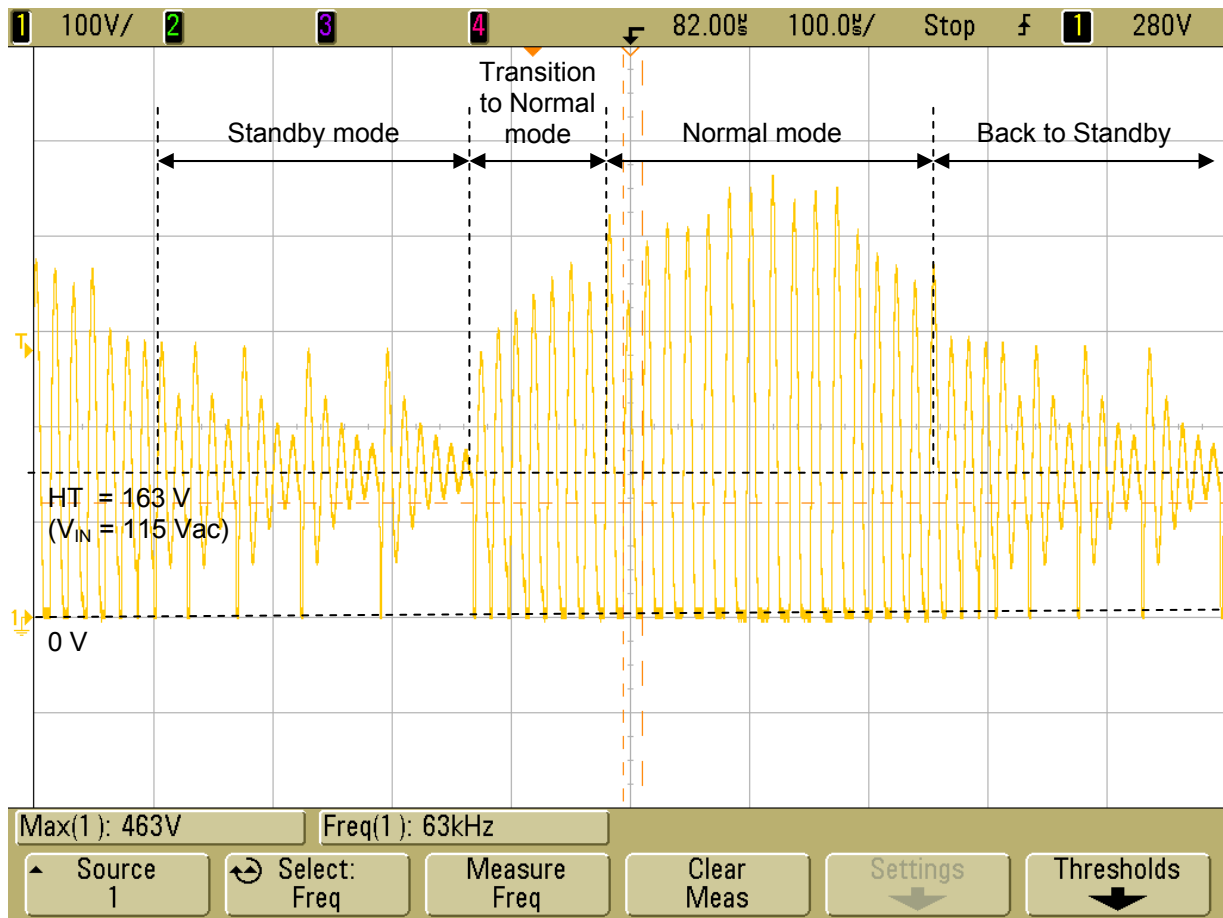

Figure 7: Q1 Collector Voltage Waveform with  $P_{OUT}$  at about 25% of Rated Power with Expected Transitions Between RDFC Controller Operating Modes Standby and Normal

### 4.5 P<sub>OUT</sub> Up to Rated Power – Continuous Normal Mode

Increase the load to about 60% of rated power, at nominal input voltage, to observe continuous operation in Normal mode. The oscilloscope display should be similar to that shown in Figure 8. An operating frequency of 40 kHz to 60 kHz is typical for RDFC designs. It can be adjusted by changing the value of the C<sub>col</sub> capacitor. Increasing C<sub>col</sub> will make the operating frequency lower, decreasing C<sub>col</sub> will make it higher. If you need to adjust the operating frequency, try changing C<sub>col</sub> in steps of about 10 % of the nominal value used.

Continuous Normal mode operation should be observed when P<sub>OUT</sub> is above about 40% of nominal rated power (P<sub>NOM</sub>). If you are still seeing transitions between Standby and Normal modes (like those in Figure 7) at or above 40% of rated power your design may emit audio noise. You can adjust the load threshold above which Normal-only mode operation occurs by changing the value of R<sub>2</sub>. Decreasing the value of R<sub>2</sub> will lower the threshold to a lower power level, increasing the value of R<sub>2</sub> will raise the threshold. If you need to change R<sub>2</sub>, try steps of 10%.

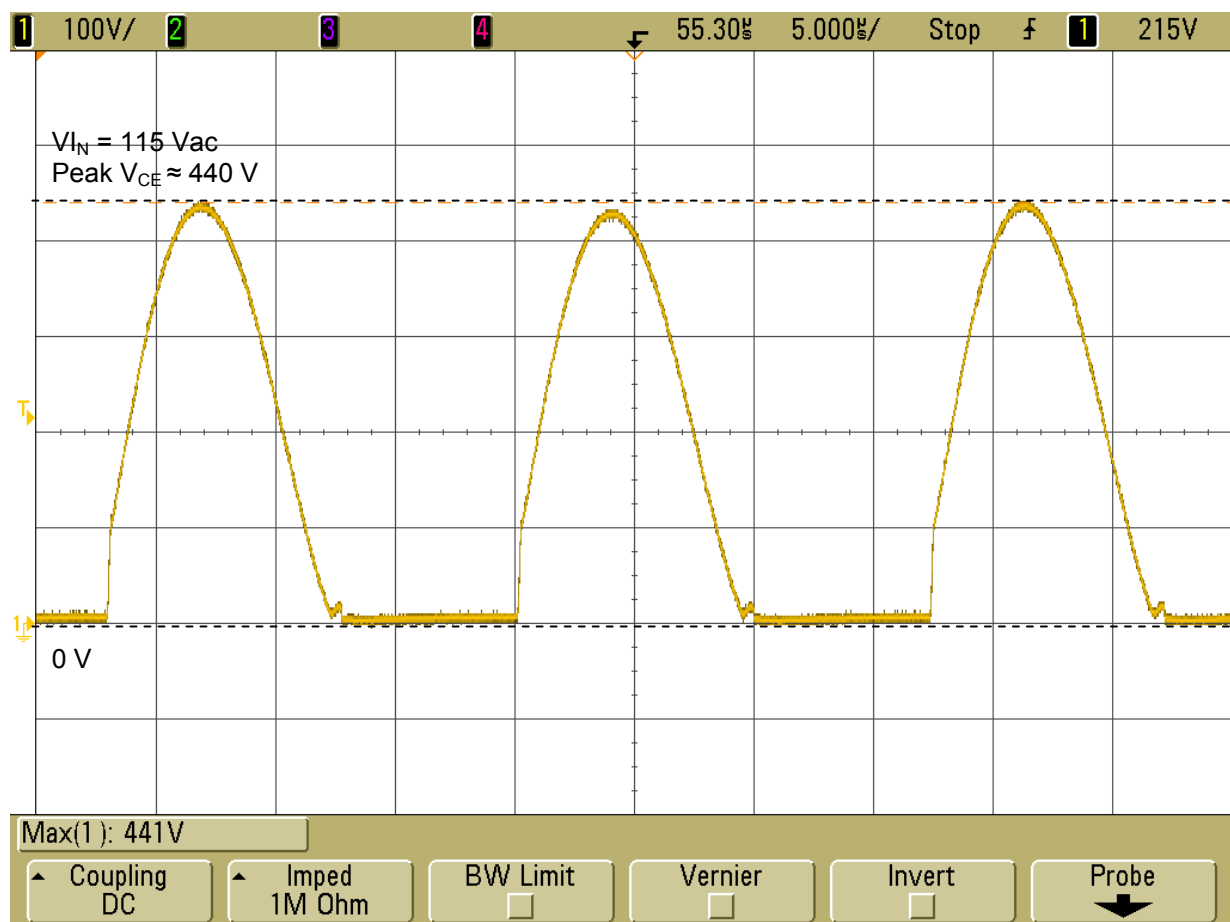

Figure 8: Q1 Collector Voltage Waveform with P<sub>OUT</sub> Approaching Rated Power (P<sub>NOM</sub>)  
(Normal Mode – Continuous Resonant Switching)

### 4.6 $P_{OUT}$ Above Rated Power - Overload Mode

If you increase the load towards 100% of the rated power and beyond, the Q1 collector voltage waveform will become like that in Figure 9. Note the steep rise in the collector voltage before the start of the more sinusoidal shape seen in Normal mode (Figure 8).

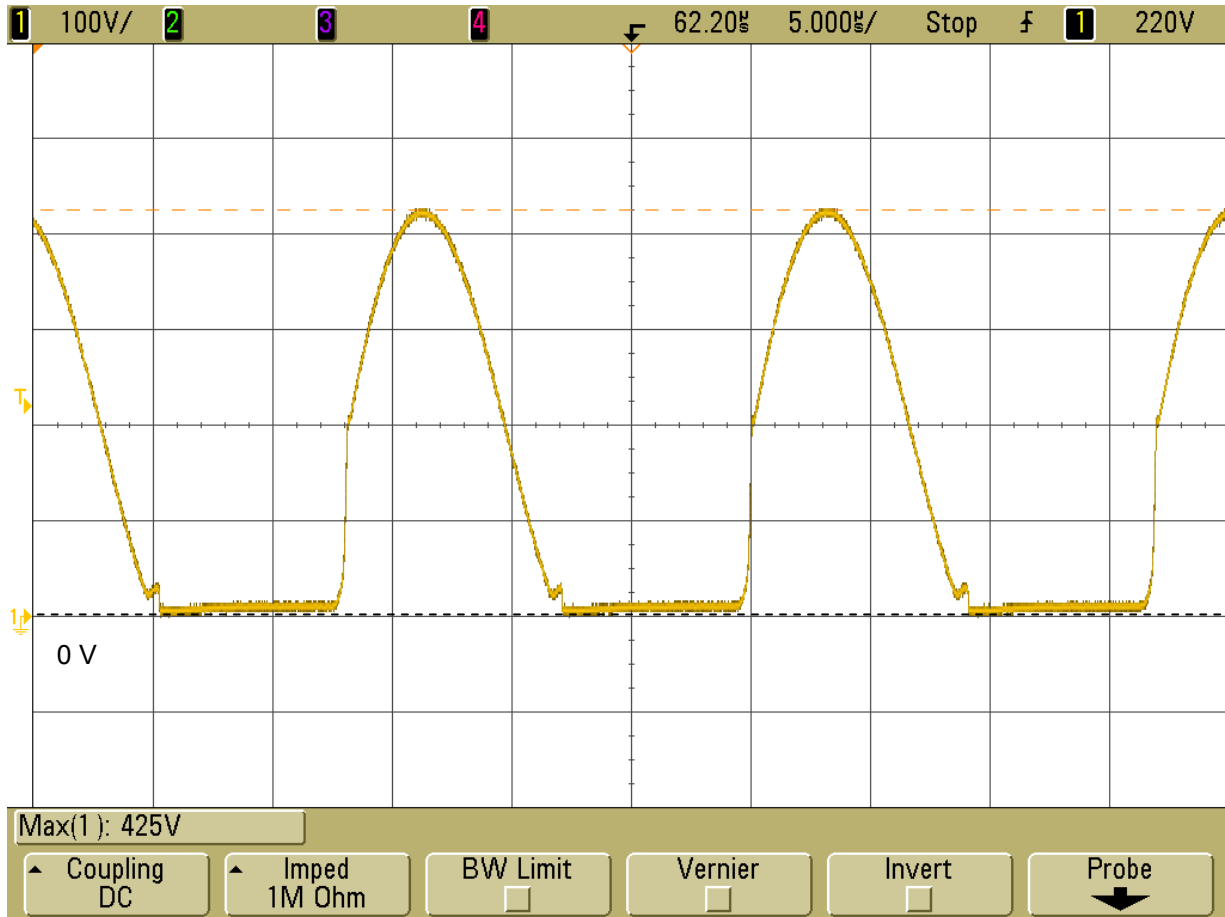

Figure 9: Q1 Collector Voltage Waveform at Rated Load and Above (Overload Mode)

### 4.7 Short Circuit Load - Foldback Mode

Increasing the load beyond about 130% of nominal rated power ( $P_{NOM}$ ) will make the RDFC controller start alternating between Foldback and Power Burst modes of operation. The Q1 collector voltage waveform should be like that in Figure 10. Foldback mode with its low duty cycle switching keeps the converter running (powered from the auxiliary winding) with low power dissipation in the application circuit and the load. The higher duty cycle switching in Power Burst mode is there to initiate resumption of Normal mode power conversion when the overload (short circuit) condition is removed.

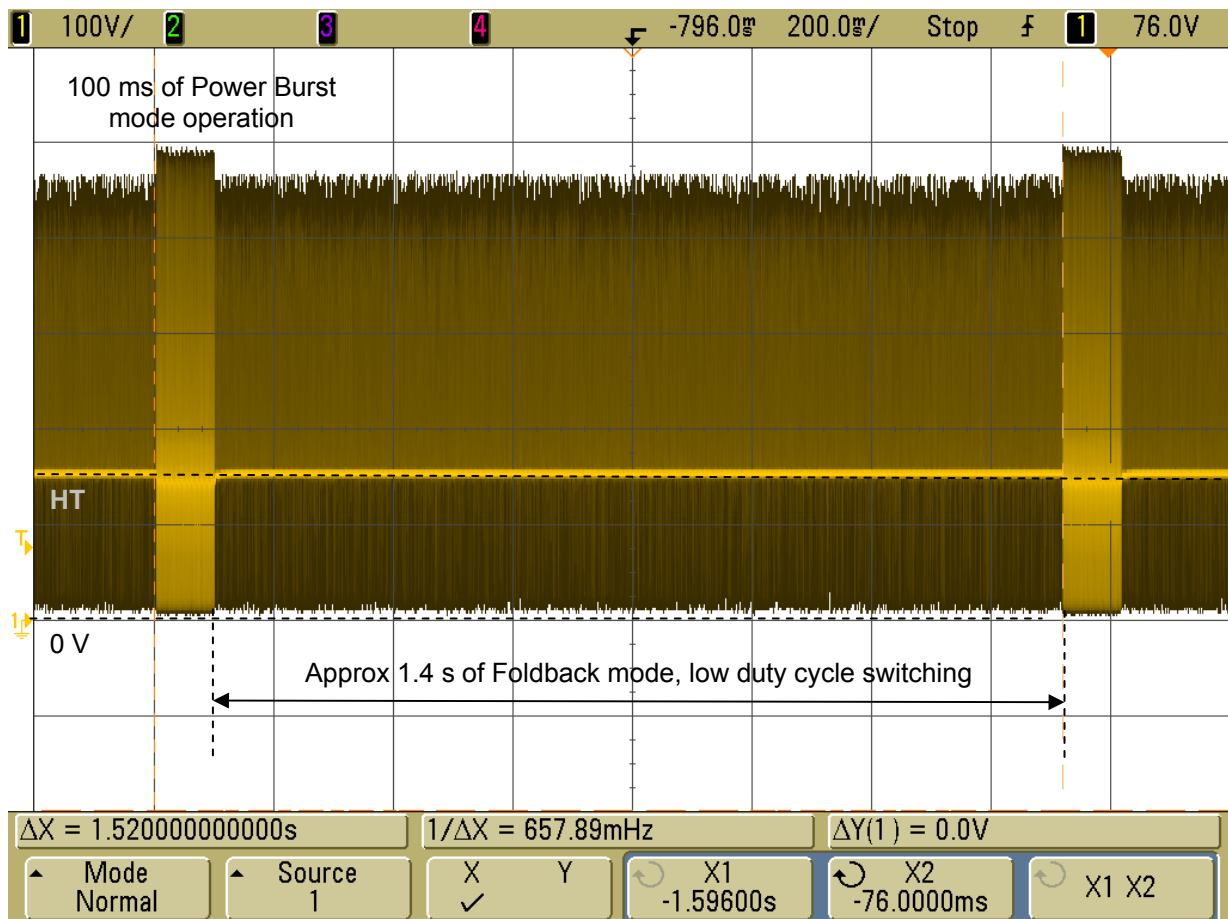

Figure 10: Q1 Collector Voltage Waveform in Foldback Mode

- You can adjust the load level at which the converter goes in to Foldback by changing the value of the Rcs resistor. To raise the threshold (i.e. enter Foldback at a higher load), decrease the value of Rcs. To lower the threshold (i.e. enter Foldback at a lower load), increase the value of Rcs.
- If the threshold at which your design enters Foldback mode is much too low the converter may fail to return to Normal mode when the short circuit condition is removed. If you experience this, raise the threshold at which the converter goes into Foldback (as described above). Alternatively, you can increase the transformer leakage inductance, which will make the transition from Overload to Foldback mode at a lower voltage.

### 5 EXAMPLE APPLICATION DESIGN

#### 5.1 Application Design Parameters

Table 20 is the target specification for a design example, made using this guide.

Parameter	Application Requirement
Input voltage ( $V_{IN}$ )	115 Vac $\pm$ 15%
Rated output power ( $P_{NOM}$ )	15 W
Nominal output voltage ( $V_{NOM}$ )	9 V at nominal mains input and $P_{OUT} = P_{NOM}$
Nominal output current ( $I_{NOM}$ )	1.7 A ( = $P_{NOM} / V_{NOM} = 15 / 9 \approx 1.7$ A)
Average efficiency ( $\eta$ )	> 80 %
Load regulation	< 15% of $V_{NOM}$
Standby power consumption ( $P_{STBY}$ )	< 300 mW with no-load at nominal mains input
Output line ripple	< 900 mV (10% of $V_{NOM}$ ) at twice line-frequency
Output switching ripple	< 150 mV (< 1.7% $V_{NOM}$ )
Load pull-up capability	Constant resistance with max $C_{LOAD}$
Maximum load capacitance (max $C_{LOAD}$ )	1000 $\mu$ F
Operating Frequency	Typically 50 kHz
Overcurrent protection	Transition to Foldback mode occurs between $I_{NOM}$ and 1.5 x $I_{NOM}$
Emissions	EN55022 class B with 6dB pass margin
Input power ( $P_{IN}$ ) with short circuit load	< 2 W
Turn-on delay	< 500 ms

Table 20: Specification for the Design Example

### 5.2 Components Selected Using The Design Guide

Table 21 summarises the components in the design example, which were determined using this guide.

Component		Guide Type/Value/Rating	Refer to Section	Actual Type/Value/Rating
RDFC controller IC		C2472PX2 (SOT23-6) C2473PX1 (SOP-8)	-	C2473PX1 (SOP-8)
Dbridge		2KBB60RPBF	Section 3.1, page 5	2KBB60RPBF, 2 A, 600 V
$C_{IN} = C_{in1} + C_{in2}$		71 $\mu$ F	Section 3.2, page 6	2 x 33 $\mu$ F, 250 V
Transformer core		E20/10/6	Section 3.3.1, page 7	E20/10/6-3C90
Bobbin		n/a	n/a	CPH-E20/10/6-1S-8P
Secondary turns $N_S$		7.7 rounded to 8	Section 3.3.2, page 7	8
Primary turns $N_P$		114 scaled to 119	Section 3.3.3, page 8	119 (= 114 x 8 / 7.7 rounded)
Auxiliary turns $N_{AUX}$		7	Section 3.3.4, page 8	7 (= 7 x 8 / 7.1 rounded)
Secondary conductor		0.8 mm	Section 3.3.5, page 9	0.8 mm
Primary conductor		0.25 mm	Section 3.3.6, page 9	0.25 mm
Auxiliary conductor		0.2 mm	Table 12, page 11	0.2 mm
Primary inductance		19 mH	Section 3.3.7, page 10	17 mH
Leakage inductance		150 $\mu$ H	Section 3.3.7, page 10	70 $\mu$ H
Output capacitor $C_{out}$	$I_{RMS}$	2.0 A	Section 3.4, page 12	2 x 25ZL470M8X20. 470 $\mu$ F, 25 V dc, ripple rating 1.25 A, ESR 41 m $\Omega$
	ESR	24 m $\Omega$		
Primary switch Q1		MJE13003	Section 3.5, page 12	MJE13003, 1.5A, 700V
Resonant capacitor $C_{COL}$		120 pF	Section 3.6, page 13	2 x 220 pF in series, 1 kV rated
Programming capacitor $C_p$		82 pF		
Output diode $D_{out}$	$I_{F(AV)}$	2.63 A	Section 3.7, page 14	SB360, 3 A, 60 V
	$V_{RRM}$	45 V		
Dcol1 and Dcol2		1N4148	Section 3.8, page 15	1N4148, 200 mA, 75 V
Rcol		220 $\Omega$		220 $\Omega$ , 0.125 W
Rcs		0.47 $\Omega$	Section 3.9, page 15	2 x 1 $\Omega$ , 0.25 W
R2		470 $\Omega$		470 $\Omega$ , 0.125 W
Raux		12 $\Omega$	Section 3.10, page 16	12 $\Omega$
Qaux		BC337-40	Table 1, page 3	BC337-40, 0.8 A, 45 V
Rdd		1 k $\Omega$	Section 3.11, page 16	1 k $\Omega$
Fuse		-	Table 19, page 17	2 A, 125Vac antisurge type
V1		-	Table 19, page 17	150 V rms rated
Rntc		10 $\Omega$	Table 19, page 17	10 $\Omega$
Rht1, Rht2		Both 2.7 M $\Omega$	Table 19, page 17	Both 2.7 M $\Omega$ , 250 Vdc
Csnub		1 nF to 2.2 nF	Table 19, page 17	1 nF, 50 V
Rsnub		22 $\Omega$ to 100 $\Omega$	Table 19, page 17	100 $\Omega$
Rout (optional)		100 k $\Omega$	Table 19, page 17	Not fitted
Cdd		1 $\mu$ F	Table 1, page 3	1 $\mu$ F, 50 V
Daux		1N4148	Table 1, page 3	1N4148
Caux		470 nF	Table 1, page 3	470 nF

Table 21: Components in the Design Example Selected Using This Guide

### 5.3 Measured Performance

Table 22 summarises the results achieved when measuring a unit of the example design. Unless otherwise stated the operating conditions are:

- $V_{IN} = 115 \text{ Vac}$
- Power in to the load  $P_{OUT} = P_{NOM}$  (rated power)
- Resistive load (load capacitance  $C_{LOAD} = 0$ )

Parameter	Application Requirement	Achieved Performance	Conditions
Nominal output voltage $V_{NOM}$	9 V	9.2 V	Nominal mains input ( $V_{IN}$ ) Delivering rated power ( $P_{NOM}$ )
Average efficiency	> 80%	82 %	Average of efficiency at 4 load points: 25%, 50%, 75%, 100% of rated $P_{NOM}$
Load regulation	< 15%	9.8 %	Load from 10 mA to $I_{NOM}$
Standby power ( $P_{STBY}$ )	< 300 mW	210 mW	No load
Output line ripple	900 mV pk-pk at twice line frequency	700 mV pk-pk	
Output switching ripple	150 mV pk-pk at switching frequency	90 mV pk-pk	
Load pull up capability	Constant resistance	OK. See section 5.8.	$C_{LOAD} = 1000 \mu\text{F}$
Operating frequency	Typically 50 kHz	58 kHz	
Overcurrent protection	Transition to Foldback mode occurs between $1.3 \times I_{NOM}$ and $1.5 \times I_{NOM}$	Transition at $\approx$ $1.3 \times I_{NOM}$	
Emissions	EN55022 class B	See section 5.14.	
Short circuit $P_{IN}$	< 2 W	600 mW.	
Load transient response	Stable operation. Output should remain within max- min regulation.	See sections 5.10 and 5.11	$C_{LOAD} = 0$ or $1000 \mu\text{F}$
$V_{IN}$ turn-on / turn-off		See section 5.12.	
Turn-on delay	< 500 ms	314 ms See section 5.12	$C_{LOAD} = 1000 \mu\text{F}$
Audible noise	Quiet under all conditions	No audible noise	Cores glued. Transformer varnished.

Table 22: Results Achieved With the Example Design

### 5.4 Example Design - Circuit Schematic

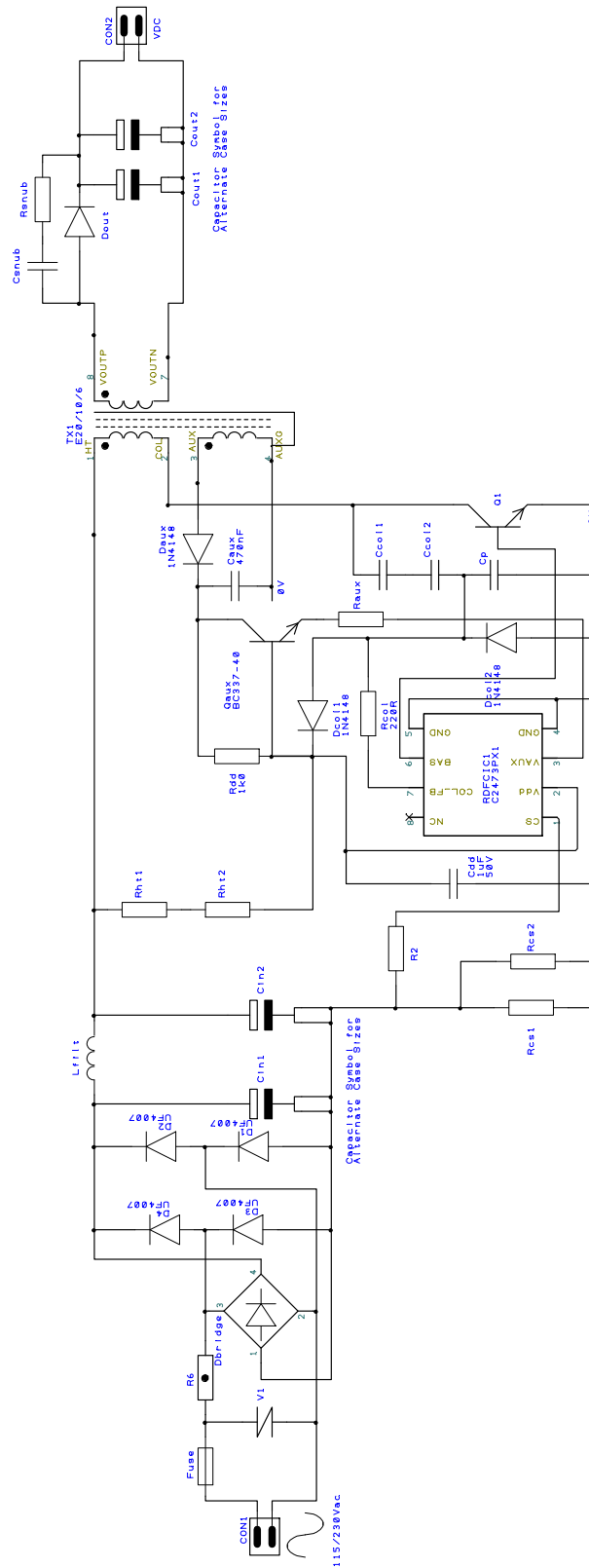

### 5.5 Line-Frequency Ripple

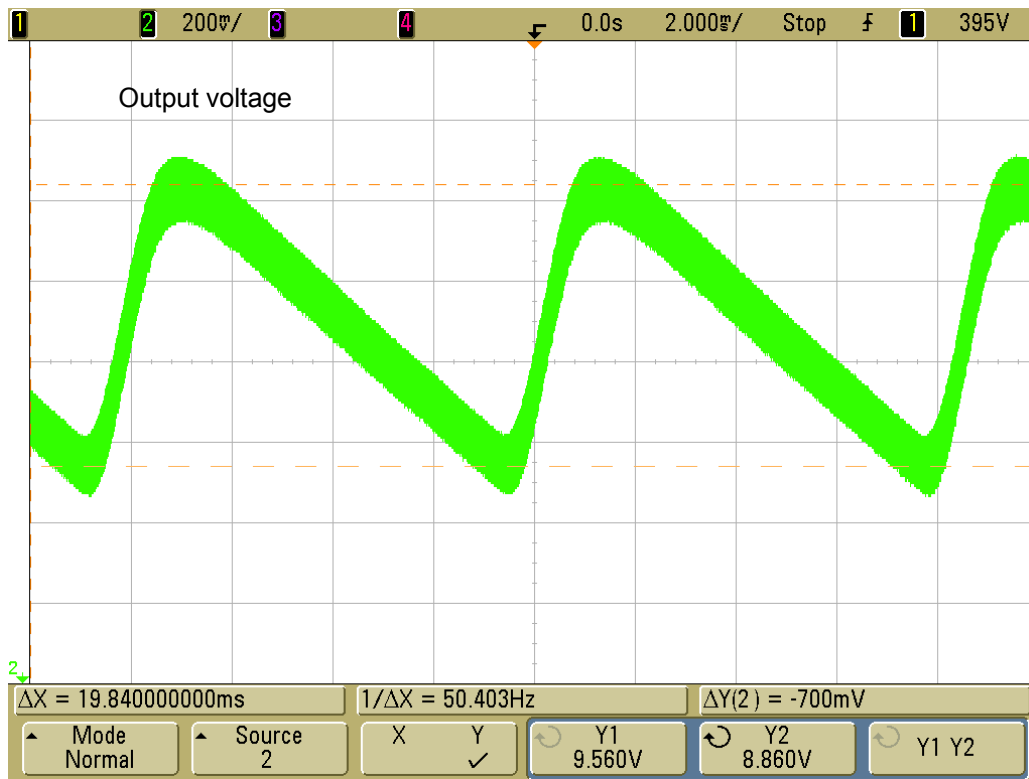

### 5.6 Switching-Frequency Ripple

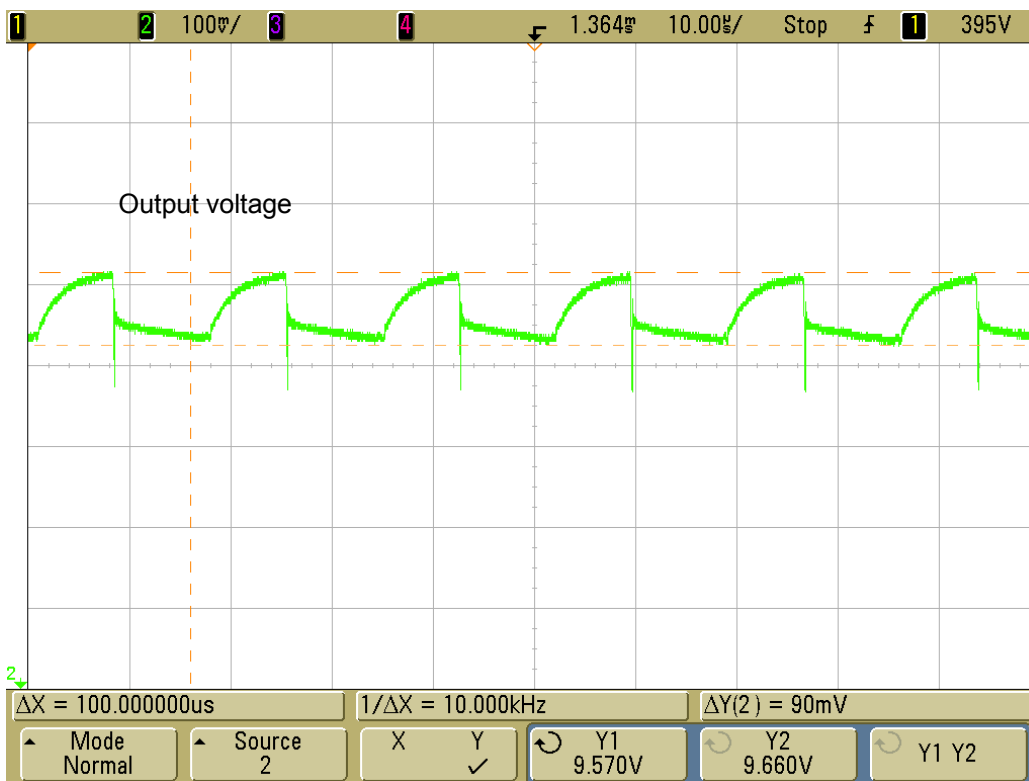

### 5.7 Efficiency

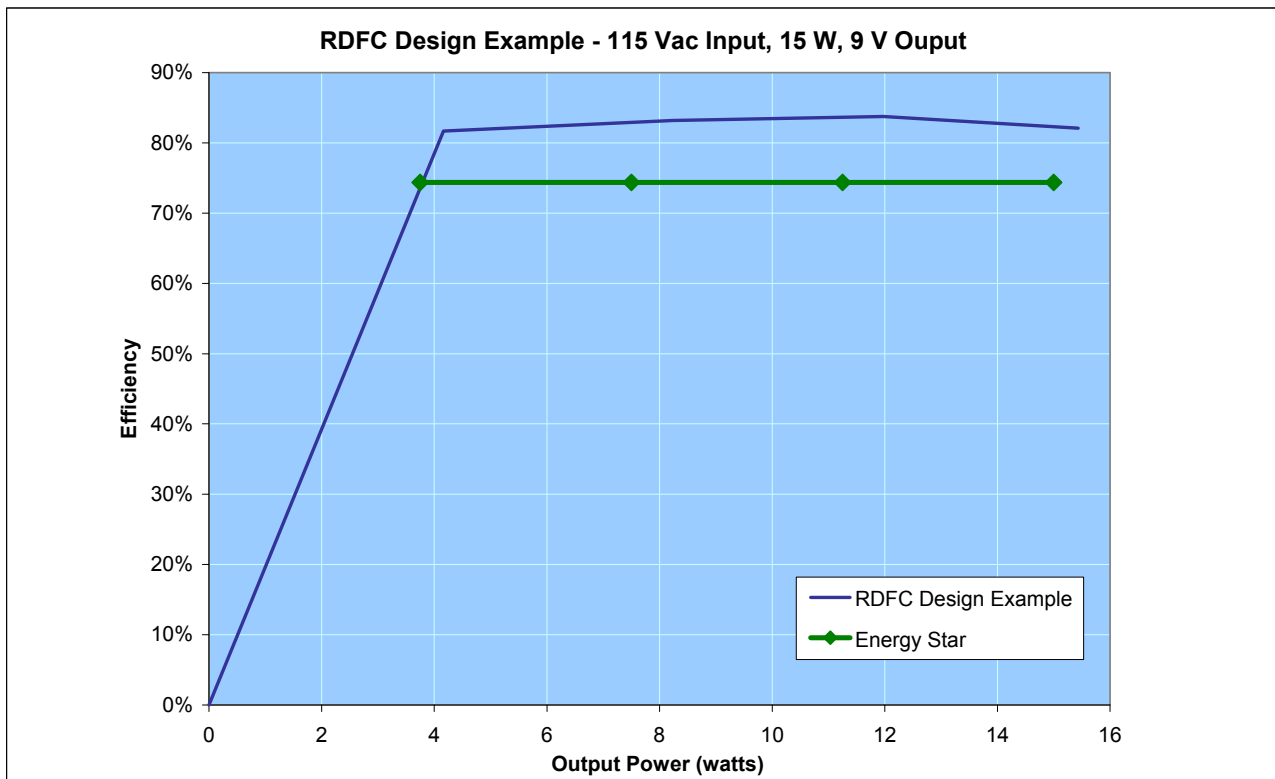

### 5.8 Load Pull-Up

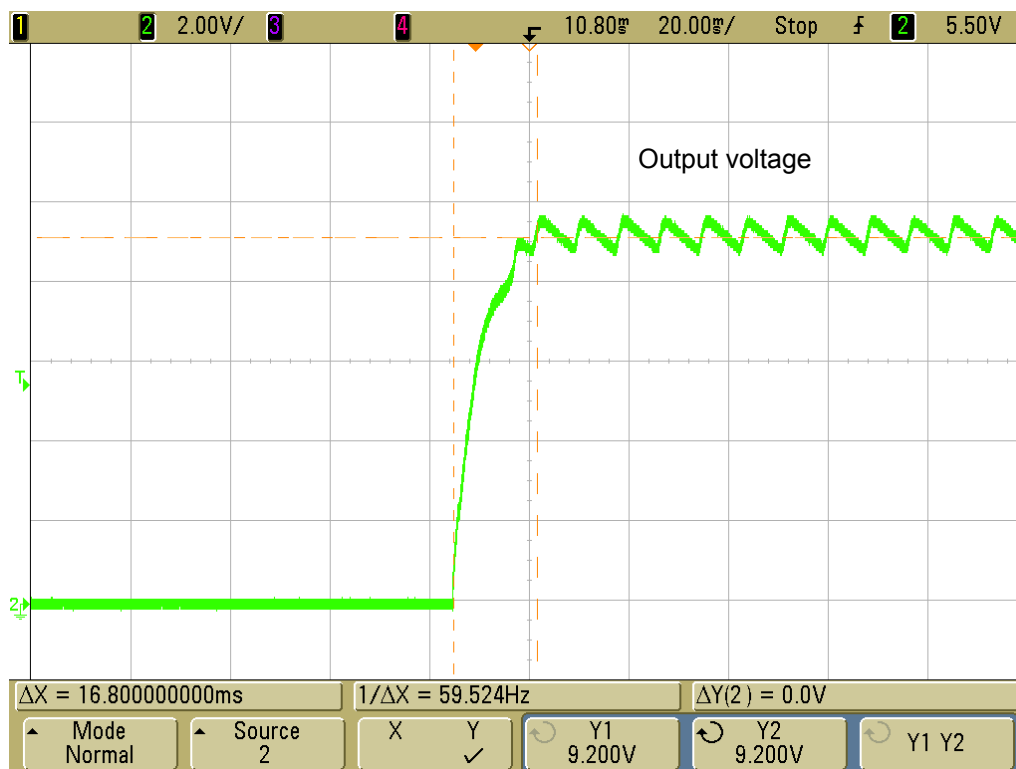

### 5.9 Recovery from Short Circuit

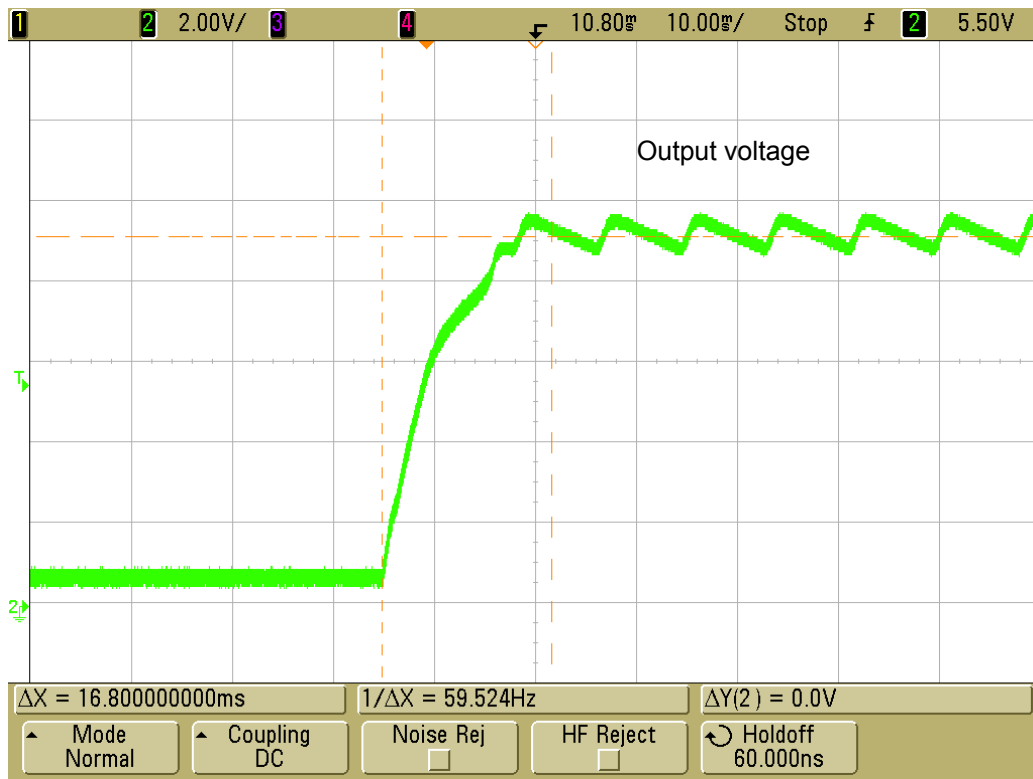

### 5.10 Load Transient ( $I_{OUT}$ Step From 10 mA to $I_{NOM}$ ) With Max Load Capacitance

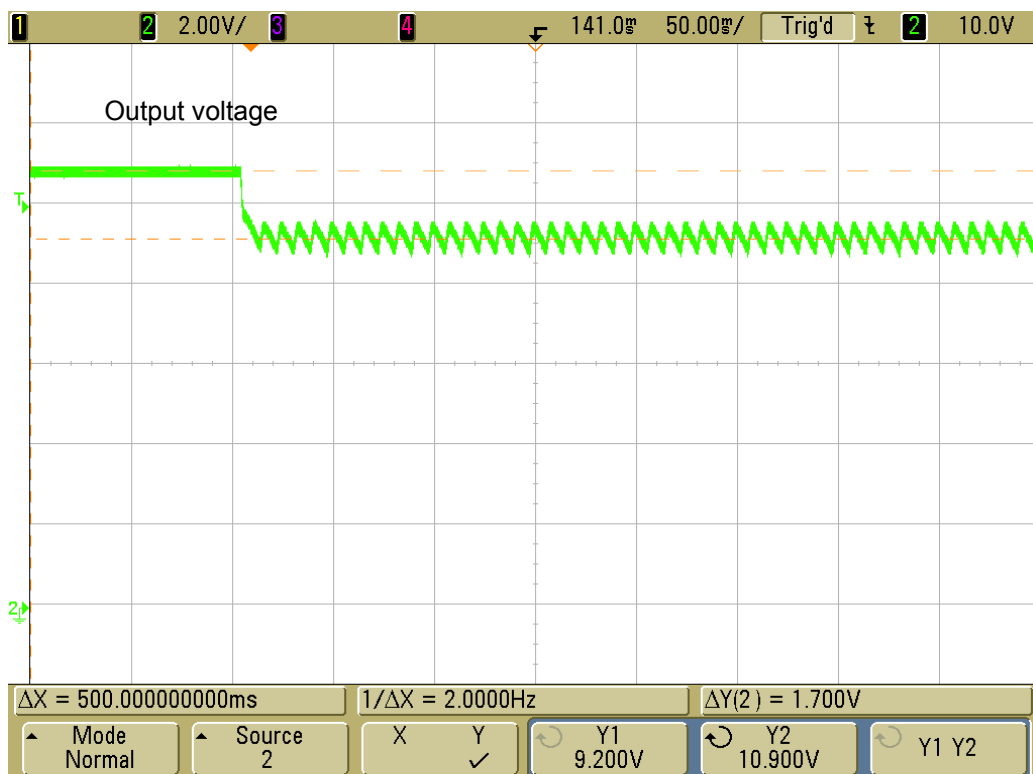

### 5.11 Load Transient ( $I_{OUT}$ Step From $I_{NOM}$ to 10 mA) With Max Load Capacitance

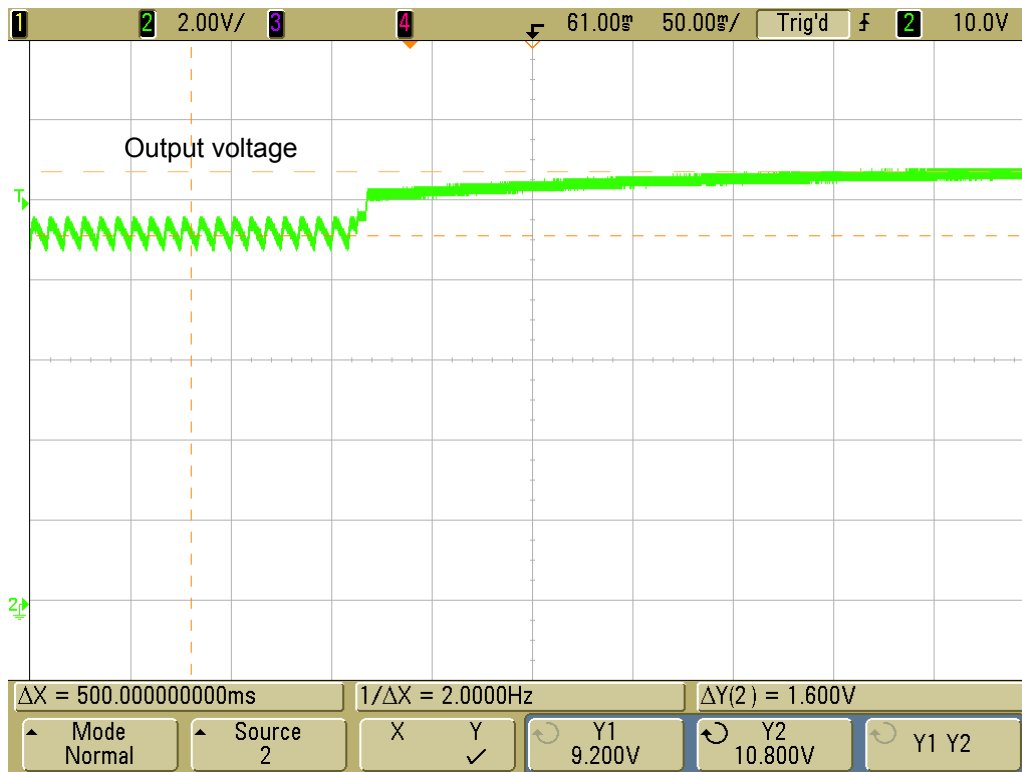

### 5.12 Turn-on Delay With Max Load Capacitance

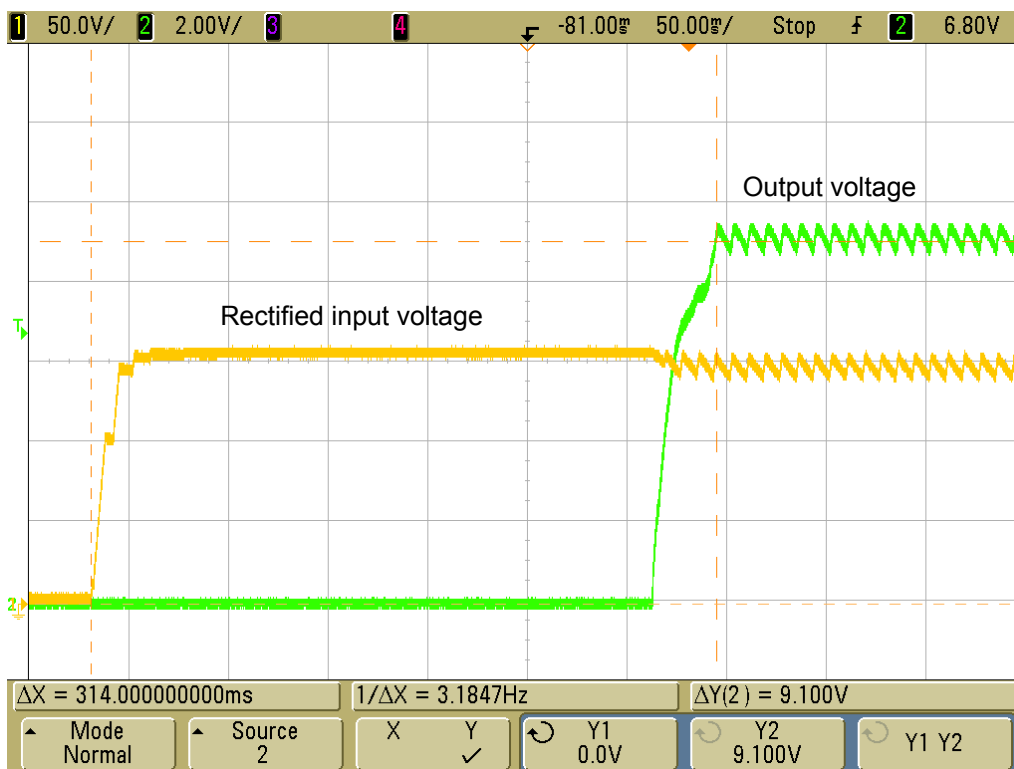

### 5.13 Operating Frequency (Plot of Q1 Collector Voltage) Measured in Normal Mode

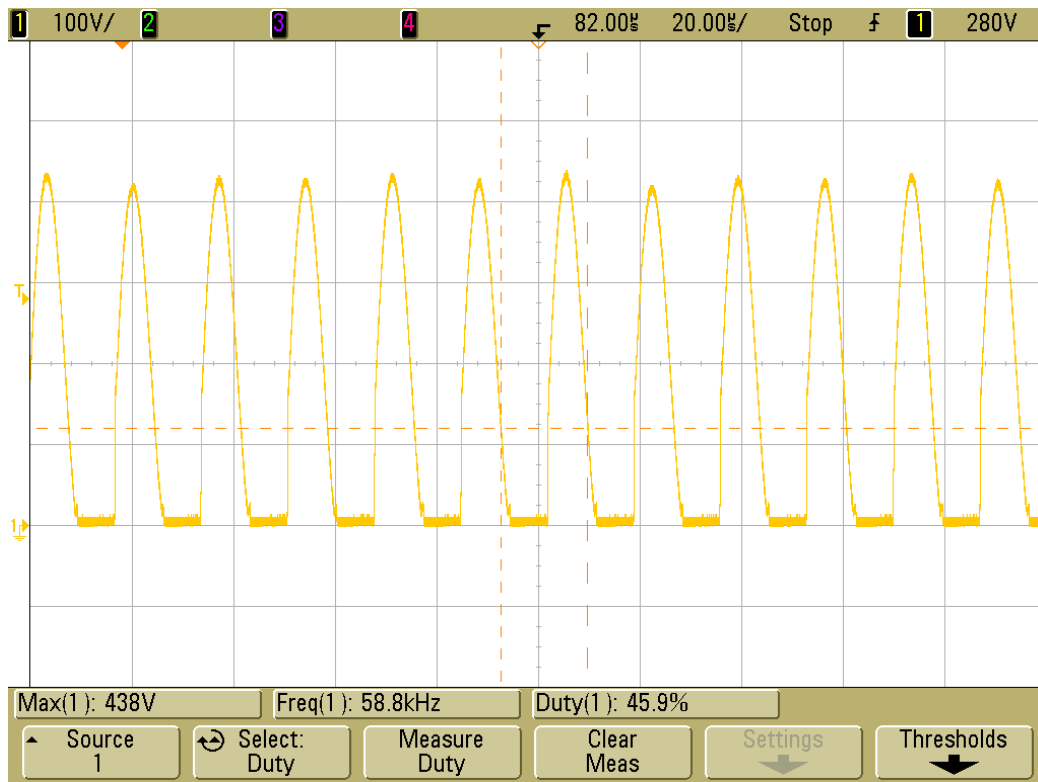

### 5.14 Conducted Emissions (EN55022 Class B Quasi Peak Limit) Pre-Compliance Test

Output 9.2V, 1.67A (rated load); 1 nF and 100 Ω snubber across Dout; output grounded; line – neutral.

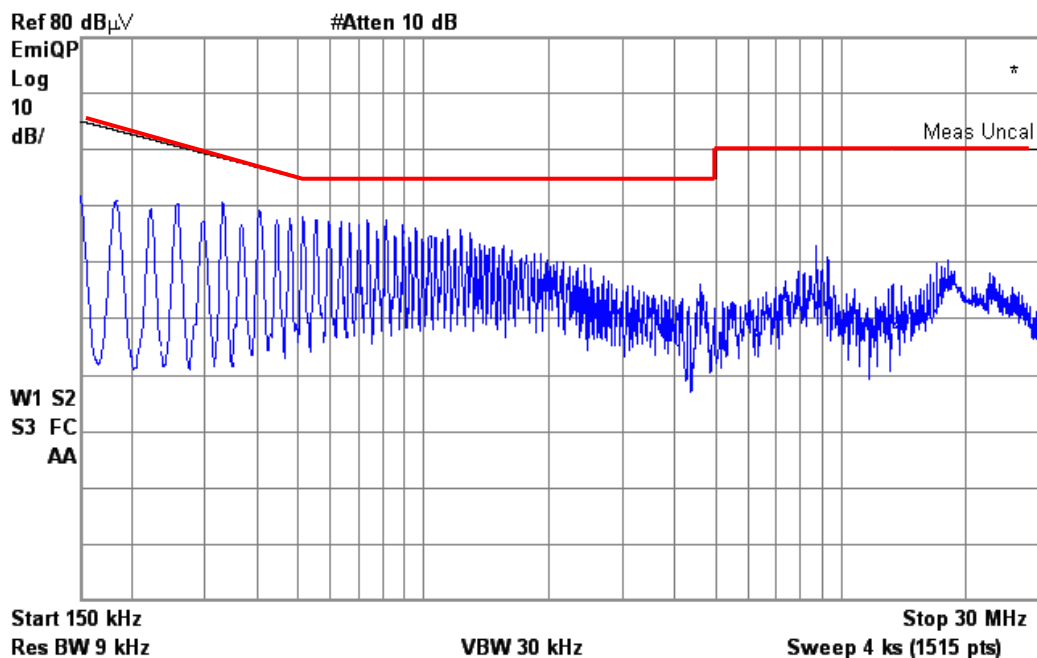

## 6 REFERENCES

- [1] RDFC C2472, C2473 Product Datasheet (DS-1423), [www.camsemi.com/support/datasheets](http://www.camsemi.com/support/datasheets)
- [2] Key RDFC Application Circuit Measurements (AN-2274), [www.camsemi.com/support/appsnotes](http://www.camsemi.com/support/appsnotes)
- [3] Power BJT Specification for RDFC Applications (AN-2276), [www.camsemi.com/support/appsnotes](http://www.camsemi.com/support/appsnotes)

## APPENDIX A DESIGN WORKSHEET

The following worksheets can be used when designing an RDFC design with this guide. Please read the following safety advice before undertaking your design.

### A.1 Safety

Offline power supplies, particularly in a development situation, can present hazards including, but not limited to, electric shock, high temperatures, fire & smoke. They should be operated and used only by competent, trained personnel. In particular:

- The unit to be tested should be checked for design and build errors before applying mains power;
- The unit under test should be powered via a suitable isolating transformer and a variac;
- Hazardous voltages are present in both normal and abnormal operating conditions;
- Insulation between high voltage and low voltage parts may not provide safety isolation;
- All connections should be regarded as LIVE and HAZARDOUS.

### A.2 Specify Your Design Parameters

Use Table 23 to record your basic design parameters.

Design Parameter	Symbol	Typical Range Achievable with RDFC	Design Target	Comments
Input voltage	$V_{IN}$	115 Vac (98 to 132 Vac) 230 Vac (196 to 265 Vac)		Application designs are specified for $\pm 15\%$ of the nominal input voltage
Rated output power	$P_{NOM}$	6 W to 40 W		RDFC chip is rated for applications in this power range
Nominal output voltage	$V_{NOM}$	5 V to 24 V		
Nominal output current	$I_{NOM}$	0.25 A to 3 A		$I_{NOM} = P_{NOM} / V_{NOM}$ Must not exceed upper end of the range achievable with RDFC.

Table 23: Record Your Basic Design Parameters

### A.3 Select Components Using the Design Guide

Use Table 24 to record the components recommended by the guide for your target design parameters

Component	Guide Type/Value/Rating	Refer to Section	Actual Type/Value/Rating
RDFC controller IC	-	-	
Dbridge		Section 3.1 on page 5	
$C_{IN} = C_{in1} + C_{in2}$		Section 3.2 on page 6	
Transformer core		Section 3.3.1 on page 7	
Secondary turns $N_S$		Section 3.3.2 on page 7	
Primary turns $N_P$		Section 3.3.3 on page 8	
Auxiliary turns $N_{AUX}$		Section 3.3.4 on page 8	
Secondary conductor		Section 3.3.5 on page 9	
Primary conductor		Section 3.3.6 on page 9	
Auxiliary conductor	0.2 mm	Table 12 on page 11	
Primary inductance		Section 3.3.7 on page 10	
Leakage inductance	150 $\mu$ H (115 Vac) 300 $\mu$ H (230 Vac)	Section 3.3.7 on page 10	
Output capacitor $C_{out}$	$I_{RMS}$	Section 3.4 on page 12	
	ESR		
Primary switch Q1		Section 3.5 on page 12	
Resonant capacitor $C_{COL}$		Section 3.6 on page 13	
Programming capacitor $C_p$			
Output diode $D_{out}$	$I_{F(AV)}$	Section 3.7 on page 14	
	$V_{RRM}$		
$D_{col1}$ and $D_{col2}$	1N4148	Section 3.8 on page 15	
$R_{col}$	220 $\Omega$		
$R_{cs}$		Section 3.9 on page 15	
$R_2$	470 $\Omega$		
$R_{aux}$		Section 3.10 on page 16	
$Q_{aux}$	BC337-40	Table 1 on page 3	
$R_{dd}$	1 k $\Omega$	Section 3.11 on page 16	
Fuse	-	Table 19 on page 17	
V1	-	Table 19 on page 17	
$R_{ntc}$	10 $\Omega$	Table 19 on page 17	
$R_{ht1}$ , $R_{ht2}$	2.7 M $\Omega$ (115 Vac) 4.7 M $\Omega$ (230 Vac)	Table 19 on page 17	
$C_{snub}$	Optimise for EMC performance	1 nF to 2.2 nF	Table 19 on page 17
$R_{snub}$		22 $\Omega$ to 100 $\Omega$	Table 19 on page 17
$R_{out}$ - optional		10 k $\Omega$ /V output	Table 19 on page 17
$C_{dd}$		1 $\mu$ F	Table 1 on page 3
$D_{aux}$		1N4148	Table 1 on page 3
$C_{aux}$		470 nF	Table 1 on page 3

Table 24: Record the Components Recommended by the Design Guide and Those Actually Used

### A.4 Measure the Performance of Your Design

Use Table 25 to record the measured performance of your design. Unless otherwise stated, use the following operating conditions:

- $V_{IN} = 115 \text{ Vac}$  or  $230 \text{ Vac}$ , depending on your design target
- Power in to the load  $P_{OUT} = P_{NOM}$  (rated power)
- Resistive load (capacitance  $C_{LOAD} = 0$ )

Parameter	Expected Performance	Achieved Performance	Conditions
Output voltage ( $V_{NOM}$ )	As selected for your design target		
Average efficiency ( $\eta$ )	> 80%		Average of efficiency at 4 load points: 25%, 50%, 75%, 100% of rated power $P_{NOM}$
Load regulation	15 % of $V_{NOM}$		Load current range from 10 mA to $I_{NOM}$
Standby power ( $P_{STBY}$ )	< 300 mW		No load
Output line ripple	10 % of $V_{IN}$ for $V_{IN} = 115 \text{ Vac}$ 5 % of $V_{IN}$ for $V_{IN} = 230 \text{ Vac}$		At twice line frequency
Output switching ripple	2.5 % of $V_{NOM}$ (pk-pk)		At switching frequency
Load pull up capability	Should pull up constant resistance load		$C_{LOAD} \leq 1000 \mu\text{F}$
Operating frequency	Typically 50 kHz		
Overcurrent protection	Transition to Foldback mode occurs between $1.3 \times I_{NOM}$ and $1.5 \times I_{NOM}$		
Conducted emissions	EN55022 class B compliance with 6 dB margin		
Short circuit $P_{IN}$	< 2 W		
Load transient response	Stable operation. Output should remain within max-min regulation.		$C_{LOAD} = 0$ or $1000 \mu\text{F}$
$V_{IN}$ turn-on / turn-off			
Turn-on delay	< 500 ms		$V_{IN} = 115 \text{ Vac}$ $C_{LOAD} = 1000 \mu\text{F}$
Audible noise	Quiet under all conditions		Glued cores. May require varnishing.

Table 25: Record the Measured Performance of Your Design

### DESIGN GUIDE STATUS

Application design information and specifications provided in this Design Guide (e.g., circuit schematics and custom wound component drawings) have not been fully developed for production and have not been subjected to safety or EMC approvals testing. Hence, design information contained herein should not be used for production without further development, verification, validation, approvals and certification appropriate for the intended application.

This Design Guide contains information relating to use of an IC product whose specification is subject to change without notice. Therefore, please always refer to the most current version of this document and the relevant IC product datasheet, available at [www.camsemi.com](http://www.camsemi.com).

### CONTACT DETAILS

Cambridge Semiconductor Ltd  
St Andrew's House  
St Andrew's Road  
Cambridge CB4 1DL  
United Kingdom

Phone: +44 (0)1223 446450

Fax: +44 (0)1223 446451

Email: [sales.enquiries@camsemi.com](mailto:sales.enquiries@camsemi.com)

Web: [www.camsemi.com](http://www.camsemi.com)

### DISCLAIMER

The product information provided herein is believed to be accurate and is provided on an "as is" basis. Cambridge Semiconductor Ltd (CamSemi) assumes no responsibility or liability for the direct or indirect consequences of use of the information in respect of any infringement of patents or other rights of third parties. Cambridge Semiconductor Ltd does not grant any licence under its patent or intellectual property rights or the rights of other parties.

Any application circuits described herein are for illustrative purposes only. In respect of any application of the product described herein Cambridge Semiconductor Ltd expressly disclaims all warranties of any kind, whether express or implied, including, but not limited to, the implied warranties of merchantability, fitness for a particular purpose and non-infringement of third party rights. No advice or information, whether oral or written, obtained from Cambridge Semiconductor Ltd shall create any warranty of any kind. Cambridge Semiconductor Ltd shall not be liable for any direct, indirect, incidental, special, consequential or exemplary damages, howsoever caused including but not limited to, damages for loss of profits, goodwill, use, data or other intangible losses.

The products and circuits described herein are subject to the usage conditions and end application exclusions as outlined in Cambridge Semiconductor Ltd Terms and Conditions of Sale which can be found at [www.camsemi.com/legal](http://www.camsemi.com/legal).

Cambridge Semiconductor Ltd reserves the right to change specifications without notice. To obtain the most current product information available visit [www.camsemi.com](http://www.camsemi.com) or contact us at the address shown above.